

Monroe Design Review Guidelines Monroe, Louisiana

Heritage Preservation Commission City of Monroe, Louisiana



Adopted 2011

Monroe Design Review Guidelines Monroe, Louisiana

2011

Prepared for the
City of Monroe, Louisiana



Thomason and Associates
Nashville, TN

ACKNOWLEDGMENTS

The Monroe Design Review Guidelines manual was prepared in association with the Monroe Heritage Preservation Commission and Monroe Planning Department Staff. Thanks are due to the many Monroe citizens who participated in the public meetings and provided comments for project completion.

Mayor

Jamie Mayo

City Council

Jay Marx

Gretchen Ezernack

Ellen Hill

Dr. Glenda Smith-Starr

Eddie Clark

Heritage Preservation Commission

Dr. Timothy Mickel, Chair

Doug Breckenridge

Cedrick Hemphill

Michael Echols, Vice Chair

Clara Sartor, 2nd Vice Chair

Melissa Zimmerman

Melanie Usrey

Planning Department Staff

Chris Fisher, AICP, Planning and Urban Development Director

Joanne C. Poret, AICP, Planning and Zoning Director

Tom Atteberry, Zoning Administrator

Alyeasha Clay, Planning Secretary/Zoning Technician

Linda Powell, Office Manager

Consultant

Thomason and Associates, Preservation Planners, Nashville, Tennessee

This project has been financed in part with federal funds from the National Park Service, Department of the Interior through the Louisiana Department of Culture, Recreation and Tourism, Office of Cultural Development, Division of Historic Preservation. However, the contents and opinions do not necessarily reflect the views or policies of the Department of the Interior.

This program received federal financial assistance for identification and protection of historic properties. Under Title VI of the Civil Rights Act of 1964 and Section 504 of the Rehabilitation Act of 1973, and the Age Discrimination Act of 1975, as amended, the U.S. Department of the Interior prohibits discrimination on the basis of race, color, national origin, disability, age, sex or sexual orientation in its federally assisted programs. If you believe you have been discriminated against in any program, activity, or facility as described above, or if you desire further information, please write to: Office of Equal Opportunity, National Park Service, 1849 C Street, N.W., Washington, D.C. 20240.

TABLE OF CONTENTS

	PAGE
PRESERVATION IN MONROE	
PRESERVATION IN MONROE.....	1
THE SECRETARY OF THE INTERIOR’S STANDARDS FOR REHABILITATION.....	8
HISTORIC PRESERVATION AND SUSTAINABILITY.....	10
HISTORIC OVERVIEW OF MONROE	11
RESIDENTIAL BUILDING TYPES AND ARCHITECTURAL STYLES	
ARCHITECTURAL STYLES.....	14
REHABILITATION GUIDELINES FOR RESIDENTIAL HISTORIC PROPERTIES	
1.0 ARCHITECTURAL DETAILS.....	23
2.0 AWNINGS.....	25
3.0 CHIMNEYS.....	26
4.0 ENTRANCES & DOORS.....	27
5.0 FOUNDATIONS.....	29
6.0 LIGHTING.....	30
7.0 PAINT.....	31
8.0 PORCHES.....	33
9.0 PORCH STAIRS & RAILING.....	35
10.0 ROOFS.....	36
11.0 PRIMARY MATERIALS.....	38
12.0 WINDOWS.....	42
13.0 WOOD.....	47
14.0 SITE FEATURES.....	49
15.0 NEW ADDITIONS.....	55
16.0 NEW CONSTUCTION.....	56
COMMERCIAL BUILDING TYPES AND ARCHITECTURAL STYLES	
BUILDING TYPES.....	58
ARCHITECTURAL STYLES.....	60
REHABILITATION GUIDELINES FOR COMMERCIAL HISTORIC PROPERTIES	
1.0 STOREFRONTS.....	67
2.0 PRIMARY MATERIALS.....	73
3.0 WINDOWS.....	78
4.0 ARCHITECTURAL DETAILS.....	82

5.0 ROOFS.....	85
6.0 FOUNDATIONS.....	87
7.0 SITE FEATURES.....	88
8.0 ADDITIONS.....	89
9.0 ACCESSIBILITY.....	92
10.0 SIGNAGE.....	95
11.0 MECHANICAL EQUIPMENT AND FIRE ESCAPES.....	101

GUIDELINES FOR NEW COMMERCIAL CONSTRUCTION

12.0 NEW COMMERCIAL CONSTRUCTION.....	103
---------------------------------------	-----

GLOSSARY.....	114
----------------------	------------

TAX CREDITS.....	124
-------------------------	------------

RESOURCES FOR REHABILITATION	126
---	------------

PRESERVATION IN MONROE

This manual lists design guidelines for commercial and residential historic properties. The guidelines include information such as common rehabilitation questions, recommendations for treatment of architectural elements of historic properties, and guidance for new construction. To familiarize historic district residents with standard elements and features, this manual uses photographs of actual buildings and architectural details within the districts.

Design guidelines offer property owners a planning tool as they consider making improvements to their properties. Design guidelines aim to provide recommendations that encourage preservation of historic resources and their architectural and historic integrity. Design guidelines provide practical assistance and direction to assure that improvements are compatible with the goals and desires of property owners and the City. Design guidelines assist property owners in maintaining and enhancing the appearance of their properties, maintaining or even improving property values, and enhancing the livability of historic areas.

The goal of the Monroe Design Guidelines is to promote preservation over alteration of historic buildings. Design Guidelines use terms such as *repair*, *retain*, *maintain* and *replace in kind*. Certificate of Appropriateness (COA) applications, forms submitted by a property owner to the City for proposed work on a historic building, will be reviewed with the following approach:

- Have the property owners first considered preserving, maintaining and repairing original or historic building features? Can rehabilitation that avoids removal of significant historic elements be accomplished?
- When replacement of historic features and elements cannot be preserved, maintained and repaired, then replacement in kind is recommended. Replace materials with the same materials and with profiles, dimensions and textures to match the original as closely as possible. Historic architectural details and materials can be documented through historic and/or physical evidence. Such documentation will aid in defining appropriate rehabilitation activities.
- Upon receipt of a COA application, the City reviews the rehabilitation project to determine impact, compatibility, and ap-



Angel statue in the city cemetery.



Entrance to Executive Tower at 141 Desiard Street.

propriateness of proposed work to the existing structure, site, streetscape and district.

- The purpose of the COA review is to insure that the proposed work will be compatible with the subject historic building or structure. Compatible rehabilitation efforts are those that respect historic buildings and districts and protect their architectural integrity and historic character.
- Exhibits that need to accompany a COA application include:
 - site plan (including landscaping, fences, and sign locations);
 - maps of rights-of-way, drives, easements, etc.;
 - plat of existing and proposed structures;
 - photographs;
 - façade elevation drawings;
 - signage (include size and height);
 - materials.

Additionally, the design guidelines acknowledge remodeling work or additions that have occurred in the past and have significance in their own right. Nineteenth century buildings may have been undergone early twentieth-century remodeling, and such work reflects the evolution of the building over time. For example, a ca. 1890 Italianate commercial building might have a storefront that was remodeled in the Modernistic style in the 1930s. The design guidelines encourage property owners to consider preserving and maintaining these types of features to illustrate the influence of later historical styles.



Design guidelines help to ensure that historic buildings such as this one at 500 Desiard Street retain their historic character and continue to be vital elements in Monroe.

PROCEDURES FOR APPLICATION OF CERTIFICATE OF APPROPRIATENESS

Before the commencement of any work in the erection of any new building, or in the structural alteration, addition to, or demolition of any existing building, any portion of which a new building, alteration, or addition is to front on any public street in any historical district in the City of Monroe, application by the owner for a Certificate of Appropriateness (CoA) therefore shall be made to the Heritage Preservation Commission (HPC), accompanied by reasonable plans and specifications. A CoA needs to be obtained before a Certificate of Occupancy and or a building permit is issued.

The application form for the CoA shall be obtained from the Planning and Zoning Division Office. The application, along with any submittals and application fee, will be submitted to the Planning and Zoning Office approximately four (4) weeks before the next HPC. The HPC meets the first Thursday of every month, unless there are no applications to review.

- (a) The applicant shall, upon request, have the right to a preliminary conference with the commission staff or the chairman or vice-chairman for the purpose of learning whether changes or adjustments to the application could make it more consistent with the HPC's standards.
- (b) Not later than ten (10) days before the date set for the said hearing, the HPC shall mail notice thereof to the applicant, the adjacent property owners within three hundred (300') feet and to all members of the HPC. The public notice shall state the location of the building or lot and the general nature of the question involved. In addition, a poster shall be placed on the site indicating to the general public the nature of the request for the posted property.
- (c) Notice of the time and place of a scheduled public hearing on an application for a CoA shall be given by publication in a newspaper having general circulation in the city at least ten (10) days before such hearing.



Prior to making any changes to porches or other building features, property owners in the historic districts need to apply for a CoA (305 Park Avenue).

- (d) At the scheduled public hearing, the applicant for a CoA shall have the right to present any relevant information pertaining to the application. Likewise, the city, the HPC and its staff, and members of the public shall have the right to present any additional relevant information pertaining to the application. (The HPC shall have the right to recommend changes and modifications to enable the applicant to meet the requirements of the HPC.)
- (e) The HPC shall act upon the application, either approving, denying, or deferring action until the next meeting of the commission. Evidence of approval of the application shall be by CoA issued by the HPC and, whatever its decision, notice in writing shall be given to the applicant and the city building official.
- (f) The issuance of a CoA shall not relieve an applicant of obtaining a building permit, variance, or other authorization from compliance with any other requirement or provision of the laws of the city concerning zoning, construction, repair, or demolition. In all such cases, applicants are encouraged to apply first for a CoA as other city agencies will be advised by the HPC in making their subsequent decisions.
- (g) No building permit which affects exterior changes to a structure in an historic district shall be issued by the building inspector prior to the issuance of a CoA by the HPC. Even if a building permit is not otherwise required by the city ordinances for construction, alteration, demolition, or relocation of any resource, a CoA from the HPC is required.

Below are examples of appropriate drawings for submittal with applications for a Certificate of Appropriateness (CoA).

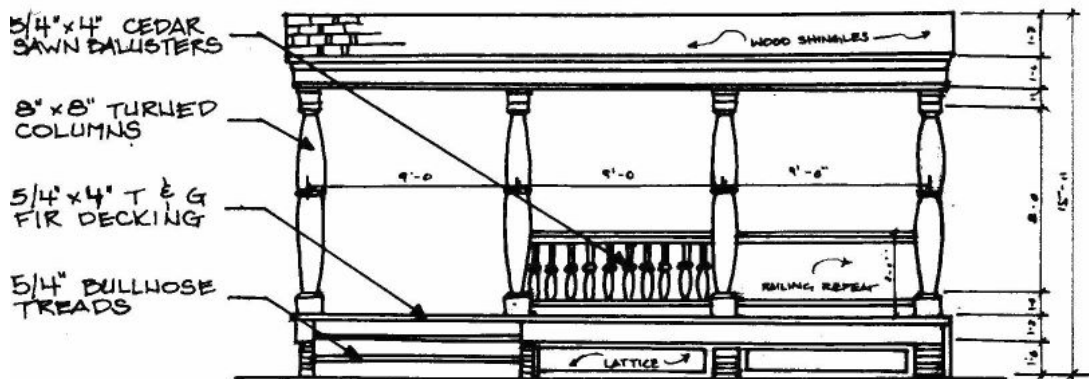
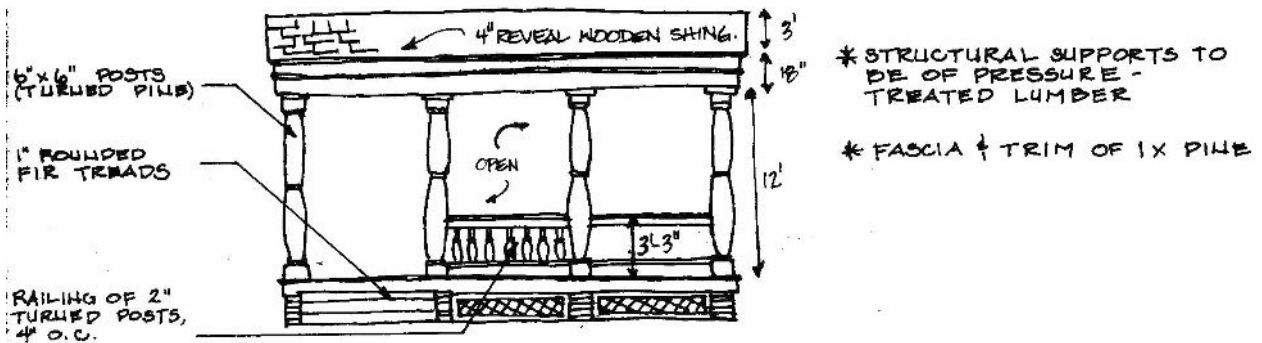

Monroe's Historic Districts

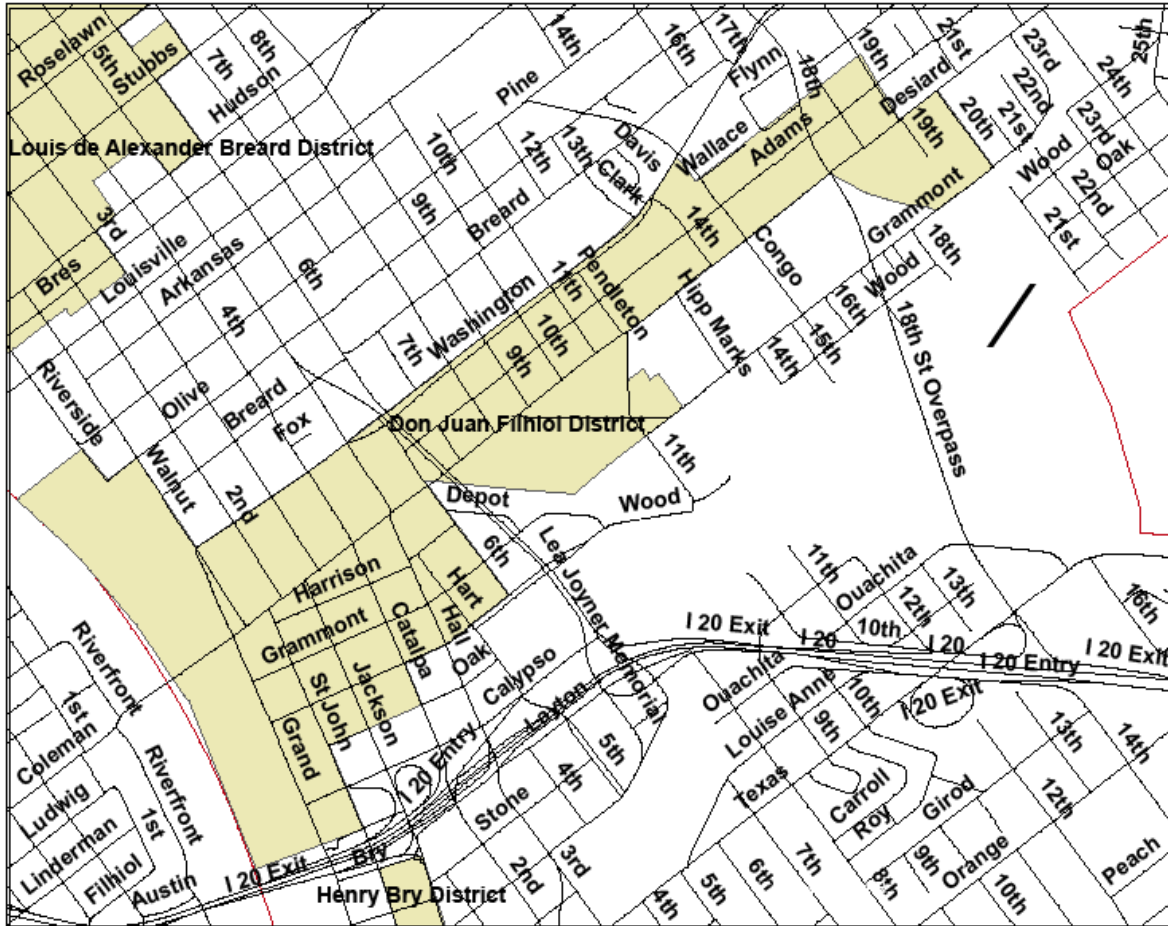

Don Juan Filhiol District

Monroe's Commercial Historic District

Monroe's Historic Districts

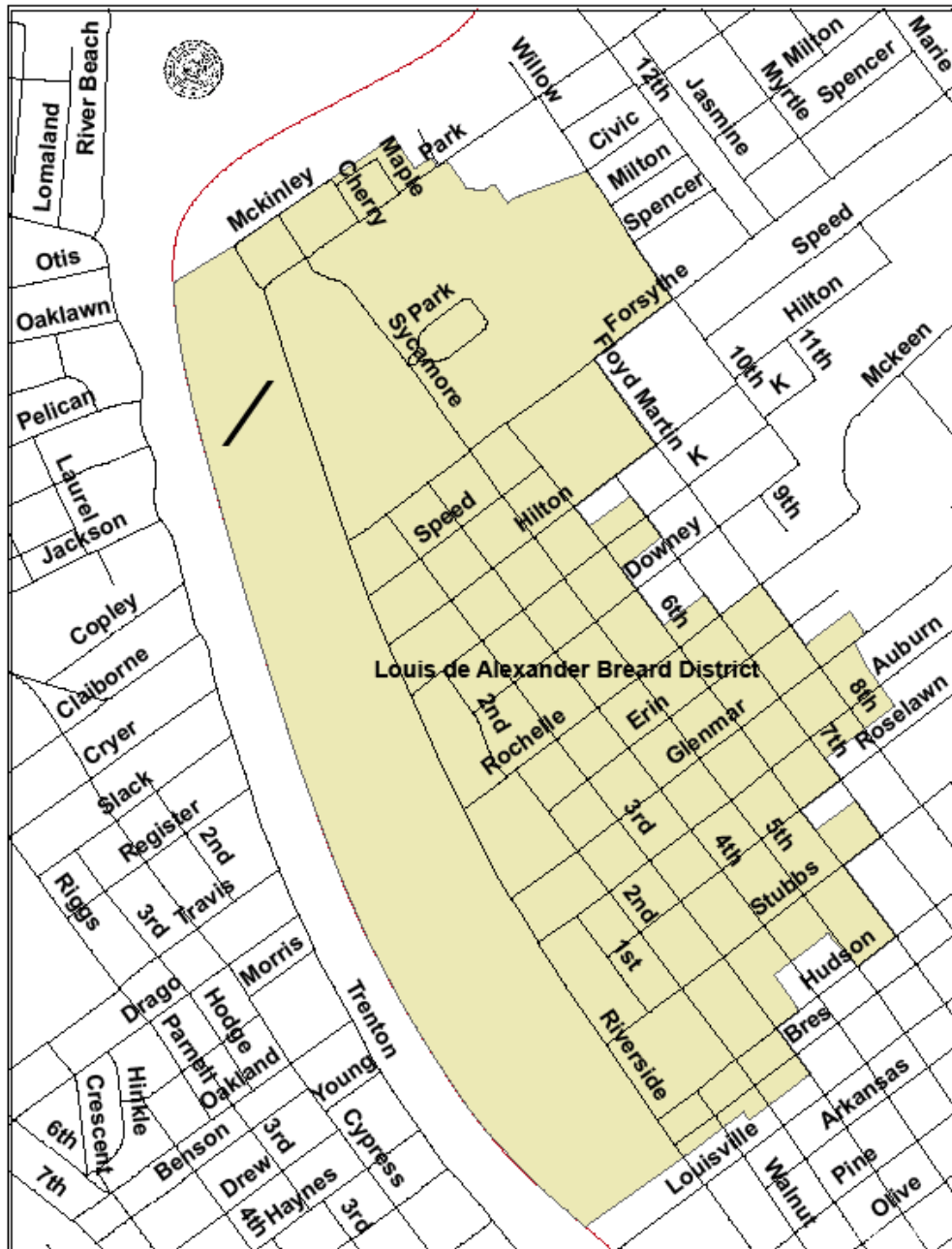

Louis de Alexander Breard District

THE SECRETARY of the INTERIOR’S STANDARDS FOR REHABILITATION

The Monroe Design Review Guidelines follow the guidelines known as the “Secretary of the Interior’s Standards for Rehabilitation,” set forth by the National Park Service. The vast majority of preservation commissions across the country use these guidelines as a basis for local design review and for projects utilizing federal funds or tax credits (see following page). The Department of the Interior originally published the “Standards” in 1977 and revised them in 1990. They pertain to historic buildings of all materials, construction types, sizes and occupancy and encompass the exterior and the interior of historic buildings. The Standards also address related landscape features and the building’s site and environment as well as attached, adjacent or related new construction.

The “Secretary of the Interior’s Standards for Rehabilitation,” are found in Appendix A of this manual. The “Standards” are also available on-line at www.cr.nps.gov/hps/tps. This web site also provides information on technical aspects of restoration and rehabilitation including “Preservation Briefs,” which are excellent summaries of various design guidelines and building rehabilitation issues provided free on-line. An illustrated version of the “Standards” is also available in paperback—*The Secretary of the Interiors Standards for Rehabilitation and Illustrated Guidelines for Rehabilitating Historic Buildings* by author W. Brown Morton is available through the National Park Service, and is online at www.nps.gov/history/hps/tps/tax/rhb/index.htm.



The Central Savings Bank at 300 Desiard Street. This building is a notable example of the Neo-classical style of the early 20th century.

Preservation and rehabilitation of historic buildings can involve added expenses. Costs can be defrayed when property owners take advantage of the following programs.

Federal Tax Incentives for Rehabilitation

A federal tax credit is available for properties listed on the National Register if they are used for the production of income. This tax credit is 20% of the total amount expended on the rehabilitation of a property. This applies to rehabilitation for apartments, retail, offices, and other income producing uses. Property owners who wish to take the tax credit must follow established guidelines for rehabilitation. These guidelines, known as the “Secretary of the Interior’s Standards for Rehabilitation,” are designed to provide guidance in the renovation of historic buildings in order to preserve their historic architectural character. The guidelines prepared for this manual are based upon these standards.

State Commercial Tax Credit

The state of Louisiana provides a 25% tax credit for the rehabilitation of certified historic buildings within a Downtown Development District (DDD) or Cultural District. Qualified applicants can deduct 25% of all qualifying rehabilitation costs from their Louisiana income taxes. The building must be used for income-producing purposes, and qualifying expenses must be a minimum of \$10,000. Rehabilitation must meet the Secretary of interior’s Standards. The state commercial tax credit may be used in addition to the federal tax credit and may also be combined with the state residential tax credit for mixed-use buildings. For more information on both tax incentives, contact the Louisiana State Historic Preservation Office at (225) 342-8160.

Residential State Tax Credit

The state of Louisiana provides a 25% tax credit for the rehabilitation of certified historic homes occupied by owners. Qualified applicants can deduct 25% of all qualifying rehabilitation costs from their Louisiana income taxes. Qualifying expenses must exceed \$20,000, and there is a cap of \$25,000 per home. The building must be the owner’s primary residence. For more information on both tax incentives, contact the Louisiana State Historic Preservation Office at (225) 342-8160.

HISTORIC PRESERVATION AND SUSTAINABILITY

Increasingly, society seeks ways to conserve resources and recycle products that were once disposed of without second thought. Historic preservation is a model of recycling on a grand and community-wide scale. The use of the term sustainability has increased as our culture begins to focus on ways to meet the needs of the present without compromising the ability of future generations to meet their own needs. Preservation of Monroe's historic buildings and districts is one of the best opportunities for sustainable development. Historic preservation is a valuable tool for respecting the environmental resources that have already been expended and protecting those not yet used. Conversely, demolishing abandoned buildings requires energy, which offsets the energy expended to construct the building in the first place.

Historic buildings represent “embodied energy”—the amount of energy associated with extracting, processing, manufacturing, transporting, and assembling building materials. Embodied energy in historic buildings includes the expense and effort used to fire bricks, cut and tool stone, transport and assemble the wood framing and prepare and apply interior plaster. Preserving historic buildings retains this embodied energy and reduces the need for new materials. The “greenest” building is one that already exists.

In addition, historic buildings were designed to be energy efficient and can be upgraded to increase energy conservation. Historic buildings, especially those constructed before 1920, are often as energy efficient as new ones. Historic buildings can also be adapted for new technology to boost energy efficiency. Solar panels are expected to become more efficient in the future and can be mounted on rear roof lines or freestanding in rear yards to provide solar energy to a property. Solar roof tiles or shingles may also be an acceptable alternative for solar heat. These roof tiles and shingles resemble traditional fiberglass and asphalt shingles and may be appropriate for rear roof lines.

Preserving historic buildings also reduces waste in landfills. Construction debris accounts for 25% of the waste in municipal landfills each year (www.thegreenestbuilding.org). Demolishing sound historic buildings is wasteful of the building's inherent materials and strains the limited capacities of landfills. Demolishing a 2,000 square foot building results in an average of 230,000 pounds of waste.



The building at 218 Desiard Street presents an excellent opportunity for a rehabilitation project

HISTORIC OVERVIEW OF MONROE

Monroe is located in Ouachita Parish, which takes its name from native inhabitants of the Ouachita tribe. The name translates as “sparkling silver water,” and the Ouachita people settled along the lower reaches of the Ouachita River. Jean Baptiste Le Moyne, a French-Canadian colonist, encountered the Ouachita here in 1700.

Present-day Monroe was originally settled in 1780 as an outpost on the Ouachita River. Don Juan Filhiol received a land grant of 1,680 acres from the king of Spain, and Fort Miro was established here. Ouachita Parish was established in 1807, in the early years following the Louisiana Purchase. A large tract, it would be divided to form nine parishes in this northern region of the state. Early settlers in Ouachita Parish included Judge Henry Bry, who arrived in 1807, and Thomas C. Lewis and Oliver Morgan, parish judges who came here in 1810 and 1813 respectively. Other early residents included R.D. Richardson, Hypolite Pargoud, Alexander Lozare, J.M.A. Hamlin, John R Dewitt, and John T. Faulk. The population of the parish in 1810 was 1,077.

The town of Fort Miro was platted in 1816. The name of the town was changed in 1819 to Monroe, named for President James Monroe, as well as the first steamboat to come up the river to the settlement. Steamboats were regularly seen along the Ouachita River in Monroe, throughout the nineteenth century, as the main form of transportation of products. Ouachita parish has vast tract of timber, such as cypress, hickory, and pine. Agricultural tracts here produced cotton, corn, and hay.

This image from a Monroe postcard depicts steamboats on the Ouachita River docking at Monroe. Photo from: <http://www.epodunk.com/cgi-bin/genInfo.php?locIndex=3487>



By mid-nineteenth century, the community of Trenton across the river had five cotton brokers handling 20,000 bales annually. Monroe also experienced a rise in river traffic and its increase in population led to its incorporation in 1855.

A serious hazard of river transportation were log jams. Snagging boats were as commonplace as steamboats on the Ouachita River. The early boats were simple wooden barges equipped with a hand-cranked wench with a lift pole. These snagging boats were operated by a crew of four or five men who scoured the river for jammed logs and floating debris. By the late nineteenth century, larger powerful boats with huge cranes for lifting replaced the earlier snagging boats.

On the eve of the Civil War, the Vicksburg, Shreveport & Texas railroad was finished as far as Monroe. On February 27, 1861, the first train came into the town. The war, however, put a halt to further expansion of the rail line. After the fall of New Orleans to the Union Army in 1862, Confederate training camps were set up in Ouachita Parish. At the same time, General Ulysses Grant has moved into northeastern Louisiana, where he wintered, preparing for his siege on Vicksburg, Mississippi the following year. Grant's presence sent refugees fleeing into Ouachita Parish and points further west. No major fighting took place at Monroe but the town suffered economically along with the region in the aftermath of the Civil War.

By 1880, the Monroe Telephone Directory lists seven residences with phones, as well as numerous stores, a livery stable, drug stores, a machine shop, and a U.S. Telegraph office. In the last decade of the nineteenth century, Monroe and Ouachita Parish were enjoying a healthy economy, still from timber and crops. Approximately 20,000,000 linear feet of timber passed Monroe annually on the Ouachita River. Of the parish's 275,245 acres, 45,738 were used for crops in 1890. More than half (28,456) of this area was dedicated to cotton. Corn was grown on the second largest area of 15,674 acres. On the remaining acreage, cane, sorghum, hay, oats, and potatoes were grown at the time.

In 1890, Ouachita Parish has a population of 17, 843. At that time, there were thirty-six public schools in Ouachita Parish, six private schools, and a central high school. Also in 1890, St. Matthew's Catholic Church association was collecting donations towards a new church building.

Monroe became the adopted home of Collett E. Woolman, who

moved his family here from Indiana in 1920. He pioneered the practice of crop dusting the boll weevil pest that devastated cotton crops across the South. In 1928, Woolman purchased an existing crop dusting company, Huff Daland Dusters, which had originated in Macon, Georgia, in 1924 and had relocated to Monroe in 1925. Woolman renamed the company Delta Air Services, which became a passenger airline in 1929. Woolman was one of four co-founders of the airline. Joe Biedenharn was another. Biedenharn had achieved success with the Coca-cola company, being the first to bottle the drink in 1894. Delta Air Service was headquartered in Monroe until 1941, when it relocated to Atlanta, Georgia.



Historic postcard of St. Matthew's Catholic Church, built ca. 1890. Photo from <http://www.alexandria-louisiana.com/monroe-louisiana.htm>

The "Ouachita Citizen" newspaper was established in 1924, and the first local radio station, KMLB, began operations in 1930. The following year marked the opening of Louisiana Junior College, now University of Louisiana, at Monroe.

In 1925-26, a unique residence was constructed for Gilbert Brian Cooley in Monroe. With his wife Selena, Cooley had moved to Monroe in 1894 and established Monroe Steam Laundry. Architect Walter Burley Griffin design the concrete Prairie style house in 1908, but Cooley did not begin construction until 1925. The house stands out as a singular example of the Prairie style in Monroe, and it also is Griffin's last project in the United States, as the architect left for Australia to design the city of Canberra. Cooley lived in the house until 1952, and his wife, until 1955. Over the next decades, the house changed hands and was divided into offices. It was restored in 1985 and listed on the National Register of Historic Places. The house was still at risk and was listed as one of the Top 10 endangered historic sites in Louisiana. In 2008, the City of Monroe purchased the building and began renovations.



Above: 1910 sketch of the design for the Cooley House (below).

By 1940, many of the blocks to the north and south of downtown had been developed and these residential areas contained some of the city's most architecturally significant properties. The downtown area thrived until the 1960s when there was a movement towards suburbia and commercial activity increasingly moved along the city's major highways. Many older commercial buildings were lost downtown due to redevelopment projects of the mid-20th century. Today, Monroe continues to be a regional economic center of northern Louisiana and has a renewed interest in planning and preservation for its downtown area and adjacent neighborhoods.



RESIDENTIAL ARCHITECTURAL STYLES

Architectural Overview

Monroe's residential architecture includes a variety of late-nineteenth and early 20th century architectural styles. Knowledge of the distinguishing characteristics of architectural styles helps guide preservation and treatment of historic buildings. The following are descriptions and examples of the district's predominant styles and forms.

Some of the earliest dwellings built in Monroe were designed in the Greek Revival style. This style was distinguished by its use of classical columns on the primary façade and overall symmetrical appearance. None of these dwellings survive in their original form or location. The majority of residential buildings in Monroe follow the stylistic designs of the late-nineteenth and early twentieth centuries. Those built during the late-nineteenth century generally display the influences of the Victorian styles. These styles placed an emphasis on decorative embellishment, especially at rooflines and porches.

By the early twentieth century, however, there was a general trend away from flamboyant, asymmetrical designs and plans. American design sensibilities reverted to the balance, simplicity, and symmetry of Classical and Colonial architecture. Another movement in reaction to fanciful Victorian styles was the Craftsman style, which expressed honesty in the use of materials, horizontality in design, and more restrained architectural detailing. Within Monroe's residential areas the Colonial Revival, Tudor Revival and Spanish Colonial Revival styles dominated from the early 1900s to the 1940s. After 1945, the Ranch style was built on some of the few remaining undeveloped lots in these neighborhoods.

With the enactment of historic preservation districts and design review, the Henry Bry and Louis de Alexander Breard Districts have experienced increased activity in rehabilitation and restoration. The preservation of Monroe's most significant architecture is now promoted by the city in order to increase property and resale values and encourage investment and economic development.

ARCHITECTURAL STYLES, continued...

Folk Victorian, 1870-1910

The Folk Victorian style is a modest vernacular version of more elaborate late-nineteenth-century styles. These frame dwellings are modest in scale and decoration, but may contain spindlework porch details or milled wood posts. They are, to some extent, defined by their forms. The forms include gabled ell, front gable, and the pyramidal square with a hip roof. Typically, they are one- or one-and-one-half-stories in height.



Example of a pyramid square at 110 Hilton Avenue.

Characteristics

- Frame construction
- Height of one or one-and-one-half stories
- Defined by their form: gabled ell, pyramid square
- May have some wood embellishment on facade



A simple gabled ell at 1907 N. 3rd Street.



This gabled ell at 1205 St. John Street is a modest design with decorative spindles and post on its porch.

ARCHITECTURAL STYLES, continued...

Queen Anne, 1880-1905

The emergence of the Queen Anne style coincided with the rise of balloon framing and mass production of wood ornamental features. These developments allowed for extravagant house plans with asymmetrical floor plan, corner towers, and wrap-around porches with exuberant details. Queen Anne houses may have highly detailed spindling, oriole or stained glass windows, roof cresting, wood shingle siding, corbelled brick chimneys with chimney pots, and irregular roof planes. Queen Anne style houses are often painted in rich, contrasting color schemes.

Characteristics

- Frame construction
- Asymmetrical floor plans
- Wrap-around porches
- Highly decorative wooden elements
- Hip roof



Example of the Queen Anne style at 918 Jackson Street.

ARCHITECTURAL STYLES, continued...

Neoclassical, 1895-1950

Around the turn of the twentieth century, there developed a renewed interest in Classical architecture. The buildings of the 1893 World's Columbian Exposition held in Chicago were largely the influence of this embrace of the classical ideals of order and balance. Such sensibilities were in stark contrast to the flamboyance and asymmetry that characterized Victorian styles. Photographs from the exposition were widely distributed across the country, thus making the Neoclassical style a fashionable trend in commercial and residential architecture.

Characteristics

- Large columns, typically with Ionic or Corinthian capitals
- Elaborate entrance, often with a pediment
- Full-height portico
- Rectangular, double-hung sash windows



Example of Neoclassical dwelling at 1116 Riverside Drive.

ARCHITECTURAL STYLES, continued...

Colonial Revival, 1900-1955

The Colonial Revival style is characterized by simplicity, symmetry, and order. The style is part of a larger movement to return to colonial roots and away from styles of the Victorian era, marked by flamboyance and asymmetry. Colonial Revival dwellings typically have rectangular plans and symmetrical facades. The roof may be gabled or hipped. Windows are often six-over-six double sashed. Doorways are reserved for any architectural detail and may include sidelights, fanlights, pediments, and columns or pilasters. The details are classically inspired, and entry porticos are common.

Characteristics

- Symmetry, balance, order
- Classically-inspired elements
- Rectangular plan
- Dormers on a gable, or hip, roof



Examples of the Colonial Revival style: 1701 N. 3rd Street (frame construction) and 1706 Riverside Drive (brick).

ARCHITECTURAL STYLES, continued...

Bungalow/Craftsman, 1905-1930

Bungalows originally emerged in California and quickly spread across the country as a popular design choice for small houses. Bungalows are generally one-story houses with large porches and open interior floor plans. Craftsman houses are usually defined as larger, two-story houses that typically have low-pitched gabled roofs with a wide eave overhang, exposed rafters, decorative beams or braces, full- or partial-width porches, and tapered posts on brick piers.

Characteristics

- One- or one-and-one-half-story
- Low-pitched roof
- Exposed rafter tails
- Brackets under roof eaves
- Wide porch with columns on piers



This Bungalow at 903 2nd Street has a full-width porch with paired posts on brick piers.



At 1510 3rd Street is an example of what is known as an Airplane Bungalow, which has a raised roof element and off-centered projecting bays with multiple gabled rooflines.

ARCHITECTURAL STYLES, continued...

Tudor Revival, 1910-1940

The Tudor Revival style was based loosely on Medieval architecture. Its popularity in American residential neighborhoods arose in the early twentieth century. House plans for this style often feature cross gable, high-pitched roofs. Exteriors can be of stucco with half-timbering, brick veneer, or weatherboard siding. The style commonly features a gable-front projecting bay with an arched entrance. Another common element is an exterior wall façade chimney. More elaborate examples of the Tudor Revival style may feature an entrance tower.

Characteristics

- Highly pitched roof, often cross gabled
- Entrance is in a projecting bay with a gable front roof
- Entrance may have an arched door
- Examples may include a tower
- Windows may be multi-light wood sash or casements.
- Exterior wall chimney on facade



The Tudor Revival dwelling at 1703 N. 3rd Street features a projecting entrance bay with a steeply-pitched roof and an arched door.



This Tudor Revival dwelling at 201 Auburn Avenue includes the style's characteristic façade chimney, projecting entrance, a cross gable roof, and both wood sash and casement windows.

ARCHITECTURAL STYLES, continued...

Spanish Colonial Revival, 1915-1940

The Spanish Colonial Revival style is based on Mediterranean architecture. Its popularity in American residential neighborhoods arose in the early twentieth century, following the opening of the Panama Canal in 1915. That year, San Diego hosted the Panama-California Exposition, celebrating architecture of Mediterranean flavor. There is not a standard floor plan associated with the Spanish Colonial Revival style, and a given dwelling may have asymmetrical dimensions and variation in façade plane and height. Other common architectural features of this style include a stucco exterior and clay tile roofs.

Characteristics

- Stucco exterior
- Terra cotta roof tiles
- Stepped parapet roofline
- Arched window or door openings
- Fixed or casement windows
- Low-pitched or flat roof



The Spanish Colonial Revival dwelling at 1403 N. 3rd Street has a low-pitched roof and arched casement windows.



Examples of Spanish Colonial Revival dwellings at 207 Erin Avenue (left) and 1303 N. 3rd Street (right).

ARCHITECTURAL STYLES, continued...

Ranch, 1945-1960

The Ranch style originated in California in the 1930s. It became widely popular following World War II. As suburbs grew, large lots accommodated houses oriented lengthwise. The typical Ranch style house is rectangular in plan. Their roofs can be hipped or gabled, with a low pitch. The houses may include attached carports or garages. Large picture windows and sliding glass doors were common features of later examples. They have minimal ornamentation.

Characteristics

- One-story
- Low-pitched roof
- Horizontal emphasis
- Picture windows
- Large chimneys



Examples of Ranch style houses at 301 Erin Avenue (left) and 1406 Riverside Drive (above).

1.0 ARCHITECTURAL DETAILS

Policy:

Preserve and maintain historic architectural details and features, as they are important stylistic elements that help to define a building's character. Do not remove or conceal historic architectural details. If repair or replacement is necessary, match replacements to the original as closely as possible in material, design, color, and texture.

DESIGN GUIDELINES FOR ARCHITECTURAL DETAILS

1.1 Retain and maintain historic architectural details and features; do not cover or conceal them.

Historic architectural features convey style, character, and craftsmanship, thus preserving and maintaining these elements is important in retaining a building's historic integrity. Likewise, the removal or concealment of original architectural details will detract from a building's historic character. Proper care and maintenance will help to ensure the longevity of architectural details and features.

1.2 Cleaning is warranted only for serious staining.

Clean architectural details and features only when necessary in order to prolong their lifespan. In general, water, mild detergent, and brushes are appropriate cleaning tools. For more complicated situations, consult with an architectural conservator, historic architect, or contractor with extensive experience working with historic buildings.

1.3 When repairing deteriorated or damaged historic architectural features, use the methods that allow them to retain their historic appearance and as much of the building's historic fabric as possible.

For decaying wood, it is appropriate to apply epoxy to strengthen damaged areas and fill in small openings. For large areas of decay, cutting out damaged areas and piecing new wood into the gap is appropriate. For lightly corroded metal features, hand scraping or chipping or use of a wire brush are appropriate ways

ARCHITECTURAL DETAILS, continued...

to remove rust and damaged paint. If corrosion is heavy, alternative methods include low pressure grit or sand blasting, flame cleaning, and chemical treatment. These latter methods are more hazardous; consult a professional. For their protection, cover adjacent materials such as brick, glass, and wood during grit blasting. Paint metal pieces immediately following rust and paint removal. Epoxies may be used to fill small gaps. It may be necessary to consult with a historic architect, architectural conservator, or experienced contractor to determine the appropriate treatment.

1.4 Do not add architectural features to buildings where none historically existed.

Architectural details and features are inherent visible elements of the historic style and appearance of a building, and just as taking away original features will alter a building's historic character, introducing elements will also compromise the building's historic integrity.

1.5 Replace missing or severely damaged historic architectural details and features with examples that replicate the original.

Match replacements to the original in design, proportion, and detail. Original details may be documented through photographs, drawings, graphics, or physical evidence. Where no such evidence exists, a simple design in keeping with the building's historic architectural style and period is appropriate.

Replication with the same materials is encouraged but substitute materials may be considered if they successfully match the original detail appearance. The use of substitute materials may be especially appropriate where they are not readily visible from the street such as along upper facades and cornices.



Trim such as eave brackets should not be removed or concealed (1015 N. 5th Street).



The highly decorative features of the Roland Filhoil House should be repaired as needed and re-painted to preserve this distinctive dwelling.

2.0 AWNINGS

Policy:

Historic awnings contribute to the character and appearance of buildings as well as promoting energy efficiency. Preserve and maintain any original awnings. Adding awnings to historic dwellings may be appropriate, taking design, placement, and materials into consideration.

DESIGN GUIDELINES FOR AWNINGS

2.1 Select awnings of traditional design.

Shed awnings are most appropriate for dwellings. Arched awnings are appropriate for arched openings. The use of bubble, concave, or convex forms is discouraged except where used originally. Awnings may be retractable or fixed in place. Select awning colors that are compatible with and complementary to the building. Avoid harsh or overly bright colors.

2.2 Place awnings so that they do not cover or detract from architectural details and elements.

If pilasters or columns define the facade, place awnings within these spaces rather than overlap the entire facade.

2.3 Use awnings of traditional materials.

Canvas or metal may be appropriate materials for awnings, depending on the date of the dwelling's construction. Metal awnings are appropriate on mid-century dwellings.



Appropriate awning style and material at 1908 Riverside Drive.



These awnings appropriately fit their openings (305 Auburn Avenue).



An awning, like this one at 201 Stubbs Avenue, should span the exact length of the opening it is to cover.

3.0 CHIMNEYS

Policy:

Retain and maintain original chimneys, even if they do not serve their historic function. Removing an original chimney lessens a property's architectural integrity. Maintain and preserve chimneys in accordance with the primary materials guidelines.

DESIGN GUIDELINES FOR CHIMNEYS

3.1 Do not remove or alter original chimneys

Preserve original chimneys even if they are no longer functioning as they are important architectural features. Do not cover chimneys with stucco or other veneers unless they were original. Concrete, slate, unglazed terra cotta and stone caps are appropriate.

3.2 Care for chimneys following the guidelines for brickwork/masonry.

When necessary use gentle cleaning methods. Use soft, historic mortar compounds that match the original when repointing.

3.3 If chimneys become unstable, rebuild the chimney matching the original as closely as possible.

Chimneys may be rebuilt or supported if they become unstable or damaged. Physical structural supports may include metal straps or brackets anchored to the roof framing. Match repairs to historic materials, shapes, mortar, material color, and brick patterns.



An exterior brick chimney at 1017 St. John Street



This detailed brick chimney at 918 Jackson Street should be maintained and preserved.

4.0 ENTRANCES & DOORS

Policy:

Entrance elements such as doors, transoms and side-lights are significant in defining a house's architectural character. Original designs should be preserved and maintained and the use of full-view storm and screen doors is encouraged so that the historic door remains visible.

DESIGN GUIDELINES FOR ENTRANCES & DOORS

4.1 Preserve and maintain original doors and entrances.

Do not remove or alter original doors, surrounds, transoms, side-lights, unless proved to be deteriorated beyond repair. Retain and maintain original framing such as jambs, sills, and headers of openings. Preserve primary doors, or those on the main façade, as they are especially important to a building's historic appearance. Do not fill or partially block historic door openings.

4.2 Keep repairs to deteriorated or damaged historic doors consistent with historic materials.

When repairing historic doors, use methods to retain their historic fabric and appearance as much as possible. Epoxy is helpful in strengthening and replacing deteriorated wood.

4.3 Replace historic doors that are beyond repair or missing with new doors that replicate the originals.

Match replacement doors to the historic door in materials and size; ensure they are consistent for the style and period of the building. Ideally, the replacement doors will have the same series of panels and have a frame of the same dimensions. Refer to documented research and/or historic photographs when replacing doors. Neighboring buildings of the same style and similar date of construction may provide guidance for identifying appropriate doors. In replacing missing original doors, select replacement doors that are similar in design to the original in style, materials, glazing (glass area) and lights (pane configuration).

4.4 Do not install new door openings where none existed.

Installing new door openings is not recommended. Ensure that new openings, when permitted, are compatible in scale, size, proportion,

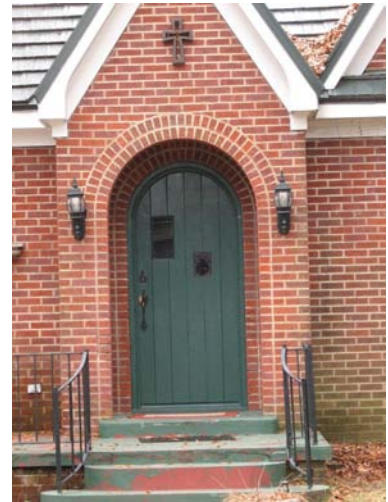

This arched entrance within a projecting gabled bay helps define the dwelling's Tudor Revival style (1015 2nd Street).



These eight-light, three-panel double doors should be maintained and preserved (1008 N. 3rd Street).

DESIGN GUIDELINES FOR ENTRANCES & DOORS, continued...

placement, and style to historic openings. Locate new openings on side or rear elevations rather than the main façade.

4.5 Use storm or screen doors if desired.

Storm or screen doors should be full view or obscure as little as possible of the door



This entrance, with original single-light double doors, sidelights, and transom, convey the historic character of the dwelling.



An appropriate screen door at 218 K Street does not conceal the original wood door behind it.



An appropriate storm door at 400 McKinley Street does not conceal the original wood door behind it.

5.0 FOUNDATIONS

Policy:

Foundations in Monroe are most often brick, stone, or concrete masonry walls. Preserve and maintain original foundation materials. Ensure foundations are repaired and maintained in keeping with masonry guidelines.

DESIGN GUIDELINES FOR FOUNDATIONS

5.1 Preserve and maintain original foundations.

Maintain original foundation materials, design and detailing. Do not cover original foundations with concrete block, plywood panels, corrugated metal, or wood shingles.

5.2 Follow masonry guidelines for cleaning, care, and repair of masonry foundations.

5.3 If replacement foundations are necessary, match the original as closely as possible.

Match replacement materials for foundations to the historic foundation and install using similar construction techniques.

5.4 Keep water away from foundations as much as possible.

Keep irrigation devices at least 3' away from foundations and direct all spray away. Also keep woody shrubs and trees away to prevent damage to historic materials. Ensure downspouts drain away from foundations through the use of splashblocks, drains, site grading etc.

5.5 Do not conceal historic pier foundation.

If infill is desired for pier foundations, use sections of lattice installed between the piers. Historically, homeowners may have added brick infill between piers, and these should remain in place.



Brick pier foundation at 1015 N. 5th Street.



Lattice is an appropriate addition between piers (1001 St John Drive).

6.0 LIGHTING

Policy:

Historic light fixtures should be retained; new ones should be understated and follow historic precedent in terms of materials and placement.



This light fixture at 100 Hudson Lane helps convey the style of the dwelling.

DESIGN GUIDELINES FOR LIGHTING

6.1 Maintain historic light fixtures.

Historic light fixtures add to the historic character of a building; preserve them if possible.

6.2 Repair or replace missing or severely damaged historic light fixtures with replacements that replicate the originals.

Original light fixture design may be documented through photographic or physical evidence. If no such evidence exists, a design that is compatible with the remaining character-defining features of the historic building is appropriate. Use of modern, low-wattage bulbs are recommended.

6.3 Keep added fixtures simple in design and appropriate to the character of the building

If modern light fixtures are desired as replacements or where light fixtures previously did not exist, ensure that they are unobtrusive, conceal the light source, and direct light toward the building.

6.4 Do not allow light fixtures to damage or obscure architectural features or other building elements.

When securing light fixtures, make sure they do not damage masonry, siding, or other historic materials. Position lights in a manner that enhances visibility without detracting from the building's historic character.



Over-head hanging light fixture at 406 Auburn Avenue.



Original light fixture at 409 Auburn Avenue.

7.0 PAINT

Policy:

Property owners are encouraged to use colors appropriate to the age and style of the dwelling. The painted finish on traditionally painted parts of buildings and landscapes like wood siding, architectural details, window sashes, and fences should be maintained.

DESIGN GUIDELINES FOR PAINT

7.1 Maintain a building's original historic painted or unpainted appearance.

Maintain the painted surface of historically painted buildings or features. Do not paint masonry buildings that have not been previously painted, unless extenuating circumstances exist.

7.2 Use non-abrasive methods to remove paint and protect historic materials during removal.

To remove paint, use non-abrasive methods such as chemical cleaning, hand-scraping, or hand-sanding. Do not use abrasive or high-pressure removal methods which are destructive. Low-heat stripping with a heat gun or heat plate, with a temperature of less than 450 degrees, may be used for paint removal. This method softens and raises paint layers by applying heat, followed by scraping and sanding.

7.3 Remove as little paint as possible.

Remove damaged or deteriorated paint to the next sound layer. Remove all paint down to the bare wood only when the paint has blistered and peeled to the bare wood.

7.4 Use appropriate kinds of paint.

Use oil paint on surfaces that have been painted with oil paint in the past; this is generally the case for historic buildings in the district. Avoid latex paint because it will likely not adhere well and because it shrinks more than oil paint when drying and can pull off underlying old paint. If latex is used, first completely prime the surface with an oil-based primer.



Queen Anne dwellings are often painted in colors that stand out and accentuate the flamboyance of the style (918 Jackson Street).

DESIGN GUIDELINES FOR PAINT, continued...

7.5 Select appropriate paint color.

Choose paint colors that complement the style and period of the house and the overall color scheme of the street. Limit the number of colors used to approximately three. Use the same color for trim including horizontal and vertical trim boards, porch columns, and window framing; a contrasting color for walls; and a darker color for doors, shutters, and Victorian window sashes.

Follow these general color schemes:

Frame Vernacular or Folk Victorian: Contrasting wall and trim colors.

Queen Anne: Deep rich colors such as green, rust, red, or brown for walls and trim. Shingles may be differently colored than walls.

Colonial Revival: Softer colors for walls with white or ivory trim.

Tudor: Often unpainted masonry surfaces or deep earth tones with contrasting and darker trim elements.

Bungalow/Craftsman: Earth tones, sometimes different colors for different floors, for walls and complementary trim.



The contrasting colors between upper and lower stories of this Craftsman dwelling further differentiate the wood shingle siding on the top floor from the weatherboard siding on the lower floor (301 Park Avenue).



Muted tones, like at 320 McKinley Street, are appropriate for Craftsman bungalows.

8.0 PORCHES

Policy:

Porches and their elements are integral in conveying the historic character and architectural style of a dwelling. Preserve and maintain original porch materials. Ensure porches are repaired and maintained.

DESIGN GUIDELINES FOR PORCHES

8.1 Retain, maintain, and repair wooden and masonry porches.

To keep porches in good repair, follow the guidelines for wood and masonry, under Section 11.0 Primary Materials.

8.2 Replace when necessary.

If damage or deterioration of an original porch is beyond reasonable repair, replace it using a design that matches the historic design. Use materials that support the historic character of the district to the greatest extent possible.

8.3 Avoid enclosure of porches.

If enclosure is desired, use glass or screens with minimal structural elements to better preserve the porch's historic transparency. Do not use solid materials that will obscure the original openings.

8.4 Use composite materials discreetly.

The use of non-traditional materials for porch floors such as wood and plastic composites may be appropriate under some circumstances. If a substitute material is used, it should be designed to resemble wood and match typical configurations of wood floor boards. These floors should not be readily visible from the street and should be painted to blend with the house colors.



The arched entry porch at 401 Auburn Avenue echoes the arched door and helps define the Tudor Revival style of the dwelling.



Original concrete porch column at 110 Hilton Avenue.

DESIGN GUIDELINES FOR PORCHES, continued...



Porches help define a dwelling's style, like this bungalow's wide porch with tapered post on brick piers. Porch elements should be preserved and maintained (107 Hilton Avenue).



The porch at 1213 St. John Drive is appropriately screened, with sections inserted within the openings between its brick posts.

9.0 PORCH STAIRS & RAILING

Policy:

Porch railings and steps are integral elements of a historic porch. Preserve and maintain all original porch materials. Ensure steps and railing are repaired and maintained.

DESIGN GUIDELINES FOR PORCHES & RAILING

9.1 Retain historic porch steps and railings

Retain historic porch steps and railings with materials that match the original. Replace porch stairs and railings with materials that match the porch's materials.

9.2 Avoid pre-cast concrete steps.

If original steps are to be replaced, pre-cast concrete steps should not be used on entrances that are readily visible from the street.

9.3 Replacement railing should be simple and in kind with original railing.

If desired, add wooden or metal handrails in keeping with the style and design of the building. Replacement railing should match the style and appearance of the original railing. Simple painted wood railings with balusters between the top and bottom rail are generally appropriate. Dimensions of replacement balusters should be at least three inches by three inches.



The porch railing at 918 Jackson Street is highly detailed and helps define the Queen Anne style.



Original concrete steps at 1207 St. John Drive.

10.0 ROOFS

Policy:

Roofs help to determine building style and are important elements of historic appearance. Retain historic roof shapes. Limit public visibility of modern features.

DESIGN GUIDELINES FOR ROOFS

10.1 Retain historic roof shapes and features.

Preserve roofs in their original size, shape and pitch, with original features (such as cresting, finials, etc.). Retain and preserve roof features such as parapets, cornices, and chimney flues.

10.2 Do not introduce new roof elements that detract from the building's historic appearance and character.

Ensure new roof elements such as skylights, solar panels, decks, balconies, and satellite dishes are not visible from the street or obscure original features.

10.3 Roof maintenance is critical to preservation.

Clean, maintain, and repair leaking roofs, gutters and downspouts. Ensure proper ventilation to prevent condensation. Provide adequate anchorage for the roofing material to guard against wind and water damage. Check seams of metal roofs and keep metal surfaces painted except for copper roofs, which are protected by their patinas.

10.4 Replace only if repair is not an option.

If overall deterioration is beyond repair, select substitute materials that will best support the historic character of the building and the district. Match original materials as closely as possible. New metal roofs should match the original as closely as possible in crimping design and seam spacing.



The Masur Museum's steeply-pitched gable roof is a signature of the Tudor Revival style. Altering this roof shape or form would adversely affect its expression of the style.



The slate roof at 1005 S. Grand Street is a unique historic element that should be preserved. Maintenance is more cost effective than replacement in kind.

DESIGN GUIDELINES FOR ROOFS, continued

10.5 Install and maintain gutters, downspouts, and splash blocks.

Retain existing boxed or built-in gutters and keep them in good working order. Repair deteriorated or damaged gutters.

10.6 If original gutters are beyond repair, install replacement gutters of an appropriate type.

The most appropriate design for hanging gutters is half round. For buildings dating from or influenced by designs from the 1940s or later, ogee gutters are also appropriate.

10.7 Locate downspouts away from architectural features and on the least public elevation of the building.

Proper placement of downspouts will protect the building and not detract from its historic character. Ensure downspouts drain away from foundations and do not affect neighboring buildings.



An appropriate gutter and downspout system at 1206 St. John Drive.



The clay tile roof at 1204 St. John Drive helps define the historic character of the dwelling.

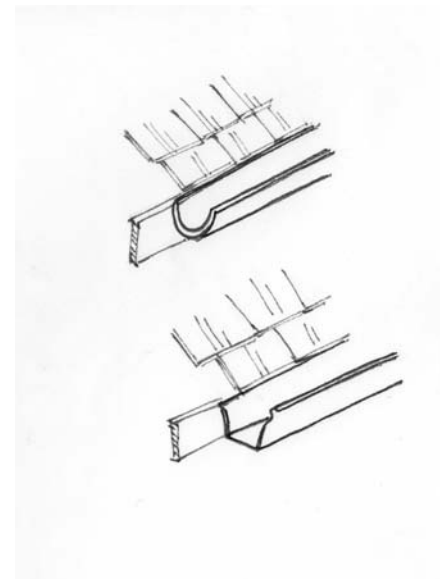

Illustrations of half-round (top) and ogee (bottom) gutter styles.

11.0 PRIMARY MATERIALS

Policy:

Preserve primary historic building materials, such as brick, wood siding, stone, or metal whenever possible. If historic materials are damaged, limited replacement with material matching the original may be considered. Proper maintenance of historic primary materials is important; avoid harsh or abrasive cleaning treatments. Do not cover or conceal historic primary materials.

DESIGN GUIDELINES FOR PRIMARY MATERIALS

Brickwork and Masonry

11.1 Preserve and maintain original brick, stone, terra cotta, cast concrete, mortar, and other masonry original to a building.

Masonry is a character-defining element of historic buildings. Different textures, finishes, and patterns contribute to a building's distinct appearance. Preserve masonry in place to retain the building's historic character. Do not cover or conceal original masonry surfaces with non-historic materials such as stucco, metal, adobe or vinyl.

11.2 When cleaning masonry, use the gentlest means possible.

Clean historic masonry only when necessary to halt deterioration or to remove graffiti and stains. Avoid any kind of harsh, abrasive cleaning such as sandblasting. The use of detergent cleansers to remove dirt or grime from masonry is acceptable. Water and a mild detergent using natural bristle brushes, and/or a non-harmful chemical solution, both followed by a low-pressure water rinse is recommended. When cleaning brick, it is advisable to test a small area first to ensure the procedure and cleaning agent are compatible with the masonry. Do not clean or remove paint from masonry with high pressure water.

11.3 Keep historic masonry visible and unpainted.

Do not paint masonry that has never been painted. If water is



The Flemish bond brick exterior at 1010 N. 3rd Street adds an element of texture to the dwelling.



The basketweave brick pattern at 409 Auburn Avenue is a unique feature of the dwelling and should never be painted or concealed.

DESIGN GUIDELINES FOR PRIMARY MATERIALS, continued...

penetrating historic masonry, water-repellent coatings can be used. The use of silicone-based sealants on masonry walls is not recommended. Silicone-based sealants do not allow the brick to “breathe” and can trap moisture within walls. Also, there are very good non-paint related treatments that are highly effective in strengthening damaged sandblasted masonry and rendering it more water repellent and resistant to the elements.

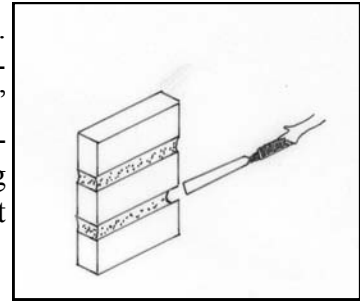

11.4 Avoid the use of power tools on historic masonry.

Power tools are damaging and are not appropriate when removing mortar. Hand tools are preferred since they allow for precision work and minimal damage to adjacent brick and stone.

Hand tools (above) are preferred when removing mortar. Avoid power tools (below) which can damage historic masonry.

11.5 Preserve original mortar when feasible, but if repointing is necessary use mortar mixes similar to the original.

Soft mortar with a high ratio of lime was traditionally used in masonry buildings constructed prior to the 1930s. Relatively low proportions of Portland cement were used if any. Harder mortars appear in more modern buildings. Match new mortar to the original mortar in width, depth, color, joint profile, and texture. When repointing historic mortar, it is important to use a mix that is softer and more permeable than the masonry units to ensure the preservation of the historic masonry.

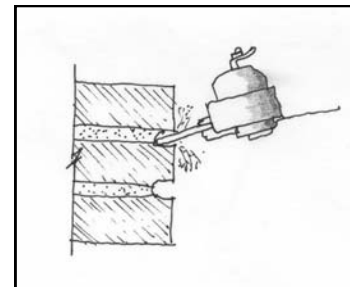

It may be necessary to consult with a historic architect, architectural conservator, or experienced contractor to determine the appropriate treatment.

Impermeable modern mortar can be inappropriate for repointing older brick and stone because they may force moisture to pass through the more permeable masonry rather than the mortar. Mechanical stresses cause expansion, contraction, settlement, and water-driven deterioration mechanisms like freeze-thaw will also be relieved in the masonry rather than the mortar if the latter is harder than the former. Modern mortars may also contain harmful soluble salts that further accelerate brick and stone deterioration.



The stucco exterior at 1201 N. 3rd Street defines the dwelling's Spanish Colonial Revival style and should be maintained and preserved.

DESIGN GUIDELINES FOR PRIMARY MATERIALS, continued...

Siding

11.6 Preserved and maintain original siding

Original siding material is a significant part of the fabric of a structure. It provides scale, texture, and shape, which help to define and characterize an architectural style. Loss of original siding can change the identity of a building in an adverse manner.

11.7 Repair original siding when necessary, and replace only if it is proven to be deteriorated beyond repair.

Regular maintenance of siding will ensure its longevity. Apply paint of an opaque stain to wood siding to provide a finished surface. If replacement of siding is necessary due to deterioration, match new siding to the original in size, placement, and design.

11.8 Synthetic or substitute materials such as vinyl, aluminum, and asbestos are not compatible materials to historic buildings built prior to about 1950, and are not allowed as replacement materials on these earlier historic buildings.

Synthetic sidings do not adequately replicate siding of traditional materials and greatly detract from a building's historic appearance. Replacement of traditional materials such as wood or brick with synthetic materials is not allowed. However, these types of materials might be suitable for buildings constructed in more recent decades if the materials were used originally.

11.9 Clean siding with the gentlest means possible.

Destructive, dangerous, and/or abrasive cleaning techniques, such as propane torching and sand- or water-blasting, are not allowed.



Retain and preserve original wood siding as at 1008 N. 3rd Street.



Original wood siding at 918 Jackson Street.

DESIGN GUIDELINES FOR PRIMARY MATERIALS, continued...

Wood Versus Vinyl Siding

- Applying vinyl siding or aluminum siding over original wood is discouraged and may not result in long-term economic value for the property owner. In terms of resale value, wood siding has the economic advantage; a recent study by *Remodeling Magazine* judges that property owners lose one out of every three dollars invested in aluminum siding when they sell their house.
- Wood and synthetic materials perform fairly equally in terms of energy conservation since most heat leaves houses through roofs, basements, windows, and doors.
- Any claims that synthetic siding is “maintenance-free” are untrue. Owners of 15 to 20 year old aluminum and vinyl siding often find that it, like wood, requires painting.
- Vinyl siding is a toxic material and is not considered "green" and friendly to the environment.
- Synthetic siding is likely to trap moisture and condensation between it and the wood underneath, leading to rotted wood and structural problems. Synthetic siding can keep the problem hidden until major damage is done.

- If you decide to use synthetic siding, you can minimize its visual impact by choosing a siding that matches the dimensions of the original siding as closely as possible. Leaving historic trim and features in place and visible also helps. Make sure that the siding is as well ventilated as possible to avoid water damage.

Maintaining Wood Siding

- Paint wood siding every five to eight years to seal it against water penetration.
- Repair or replace damaged sections. Epoxies can be helpful.
- For its best appearance, keep wood siding clean by using a strong stream of water from a garden hose or by using household detergent and a medium soft brush.
- Allow sunlight and air to reach siding to prevent mildew.

For more information on general maintenance and painting of wood siding, see the preservation brief at <http://www.nps.gov/history/hps/tps/briefs/brief10.htm>

12.0 WINDOWS

Policy:

Preserve, maintain or repair original windows. Do not conceal, enclose or cover historic windows. If replacements are necessary due to deterioration, match the historic window in size, and number and arrangement of panes, or lights. Ensure replacement window frames are of the same material, such as wood or metal, as original windows. Do not introduce new window openings on facades.

Why Preserving Original Windows is Recommended and Makes Economic and Environmental Sense

Nationally-accepted principles for preservation recommend the retention and careful treatment of historic wood and metal windows unless the windows are clearly proven to be deteriorated beyond repair. The reasons for preserving original windows include:

Windows are a significant part of the original fabric of historic structures. They provide important architectural qualities that define and characterize an architectural style and time period as well as the scale of a building and/or historic district. The loss of windows alters the defining qualities of the historic fabric, structure and/or historic district. Rebuilding historic wood windows and adding storm windows makes them as efficient as new vinyl windows and more than offsets the cost of installation. A weather-stripped wood window with an added storm window is as energy efficient as most new vinyl thermo-pane window, as noted in the comprehensive window study “Testing the Energy Performance of Wood Windows in Cold Climates: A Report to The State of Vermont Division for Historic Preservation Agency of Commerce and Community Development,” presented in 1996.

- Typically, windows only account for 10% to 15% of energy loss and the payback for installing new windows can be decades.



Original four-over-four wood sash windows at 1205 St. John Drive.



Original stained glass window at 918 Jackson Street.

WINDOWS, continued...

- All windows expand and contract with temperature changes. However, vinyl expands more than twice as much as wood and seven times more than glass. This often results in failed seals between the frame and glass and a significant performance reduction. Vinyl windows have a high failure rate – more than one-third of all windows being replaced today are less than ten years old (Source: *Fine Homebuilding Magazine*, October/November, 2004).
- Often vinyl windows do not look like historic wood windows; their texture and thinness are inappropriate for Monroe’s historic districts. A more acceptable alternative, if the original windows are beyond reasonable repair, are wood windows with aluminum cladding with a baked enamel finish. The aluminum protects the wood frames, and the finish softens the glossy appearance of the aluminum.
- Historic wood and metal windows are sustainable. They represent embodied energy, are made of materials natural to the environment and are renewable.
- Vinyl windows cannot be recycled and are detrimental to the environment when they are thrown away.
- The old-growth lumber used in historic window frames can last indefinitely, unlike new-growth wood or vinyl.



Original two-over-two wood sash window with ornamental hood at 120 S. Grand Street.



Original casement windows at 1400 S. Grand Street.

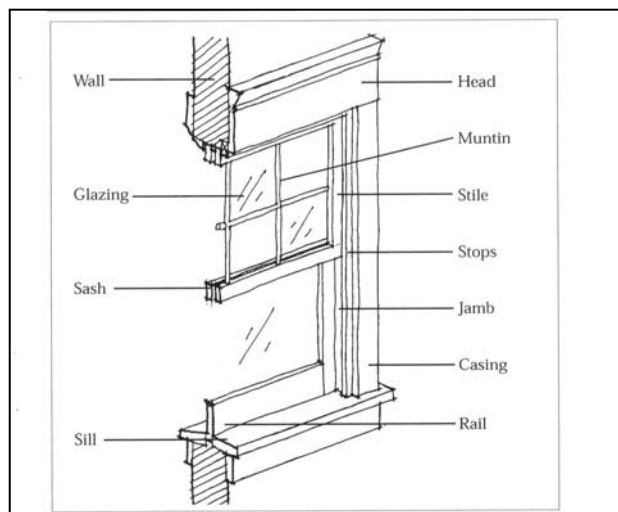

Profile of a sash window noting its different elements.

DESIGN GUIDELINES FOR WINDOWS

Treatment of historic wood windows

12.1 Preserve and maintain original windows.

Window openings, windows, window details, and the size and shape of these elements help establish rhythm, scale and proportion of buildings and reflect architectural style and character

12.2 Repair deteriorating wood windows as needed. When possible, replace missing panes or damaged sashes rather than entire windows.

Retaining as much of the historic window material and detail as possible will help protect the building's historic character and appearance. Replace only those elements necessary. Use epoxy to strengthen deteriorated wood.

Treatment of historic steel, aluminum, bronze and other metal windows

12.3 Preserve, maintain and repair original windows.

Metal windows such as steel, aluminum and bronze were introduced and widely used into the mid-twentieth century. Preserving these materials as well as their original designs and details is recommended. Make repairs with materials that match the original as closely as possible.

Metal windows are sometimes replaced due to concerns over energy conservation. In the 1950s and 1960s, aluminum windows were often installed with single glazing on large curtain walls resulting in poor energy efficiency. The energy performance of metal windows can be enhanced by applying weather stripping and security fittings. Spring-metal, vinyl strips, compressible foam tapes and sealant beads are other weather stripping options. A window's original single glazed glass may also be replaced with thermal glass panes (3/8" to 5/8" thick) provided that the rolled metal sections are at least 1" wide and the design of the historic window is retained. Another option for improving energy efficiency is the installation of storm windows, which help reduce heat loss from the building during winter and cool air loss during the summer. In this way, the house's heating and cooling systems do not have to work as hard, reducing energy use.



The original casement windows of this sunroom help define the historic character of the dwelling (400 McKinley Street).

DESIGN GUIDELINES FOR WINDOWS, continued...

Replacement Windows

12.4 Replace windows only if they are beyond repair, and match replacements to the original in size, materials, and number and arrangement of lights.

Wood is the preferred material, but other acceptable alternatives may be aluminum clad wood or aluminum. Most major window manufacturers have appropriately sized wood windows for historic residential buildings. Replace historic metal windows with like materials.

In addition to materials, the primary concern for replacement windows is matching the appearance of a historic wood or metal window through appropriate dimensions, depth of frame, and the appearance of true divided lights. True divided lights for windows are preferred or windows with lights that are bonded to the glass with spacers and appropriate grid profiles.

It is possible to consider alternative materials in some special cases, if the resulting appearance of the window will match that of the original in terms of design, finish of the material, and its proportions and profile.

Reuse serviceable window hardware and locks.



Original vertical-three-over-one wood sash windows help convey a dwelling's historic character. Replacing them would diminish the building's architectural integrity (100 Hudson Lane).

DESIGN GUIDELINES FOR WINDOWS, continued...

Storm Windows

12.7 Install storm windows and doors of appropriate material and design so as not to detract from the building's historic appearance.

Select storm windows and doors of wood, baked-on enamel or anodized aluminum, and ensure they fit within the window frames, not overlap the frames. Select storm windows of full-view design or with the central meeting rail at the same location as the historic window. Select storm doors of full-view or half-light design. Ensure they are compatible with the existing door and do not obscure or cover architectural features.

12.8 Retain historic blinds or shutters.

If new blinds or shutters are installed, use ones that are constructed of wood and sized and installed like historic working ones.



Storm windows like at 406 Auburn Avenue protect original windows and provide an insulating effect that make retaining historic windows more cost effective than replacing them.



Like storm windows, screens may be fitted into original window openings (1207 St. John Street).



Retain historic shutters like these at 1005 N. 3rd Street.

13.0 WOOD

Policy:

Preserve and maintain original wood elements. Exposure to water compromises the longevity of wood, therefore stringent and regular observation for leaking roofs, gutters, and caulking is necessary to keep wood surfaces protected.

DESIGN GUIDELINES FOR WOOD

13.1 Prevent water damage to wood surfaces.

Eliminate excessive moisture problems by repairing leaking roofs, gutters, and downspouts. Secure or replace loose or faulty flashing and insure proper ventilation. Prevent water from pooling near foundations through proper drainage. Recaulk where rainwater might penetrate a building. These areas include junctions of dissimilar materials or construction joints such as siding and corner boards. Remove old caulk and dirt before recaulking and use a high quality caulk such as one made with polyurethane. Do not caulk under individual siding boards or windowsills.

13.2 Maintain paint on wood surfaces.

Keep all wood surfaces primed and painted in accordance with guidelines for paint in order to prevent deterioration from moisture.

13.3 Take pre-emptive measures when rot is first observed.

If wood is beginning to rot, dry it thoroughly and treat it with fungicide. Waterproof it (two to three applications of boiled linseed oil with 24 hours of drying time between coats has been quite successful), then fill any cracks and holes with putty and sand. Caulk between the wood members when necessary, then prime and paint the wood.



Porches like this one at 1205 St. John Street often have an abundance of wood elements, including milled posts, railing and balusters, and ornamental trim.

DESIGN GUIDELINES FOR WOOD, continued...

13.4 Use epoxy to fill in partially decayed spots.

If wood is partially decayed, semi-rigid epoxy can be used to fill in and strengthen areas where wood has decayed. Allow the epoxy to harden. Then fill, patch, sand, and paint the entire area. Caulk between the wood members when necessary, then prime and paint the wood.

13.5 Re-secure warped boards.

Convex warped boards can be re-secured by drilling several holes along the centerline of the board. Insert countersunk screw (countersink enough so that screw heads end up below the surface of the board). To avoid splitting the board during the process, wet it down. Then gradually tighten the screws to pull the board flush, doing so gradually, perhaps even over several days.

For concave warped boards, use a row of finishing nails at both the top and bottom edges to pull the edges back down. Countersink the nail heads and fill the holes with putty. Then sand and paint.

13.6 Replacement may be necessary.

If a portion of a wood board is deteriorated beyond repair, remove the damaged section with a circular saw or hacksaw, cutting out as minimal a portion as possible. Replace the removed section with a new board that matches the existing boards in size and profile. Nail it in place, countersink the nails, putty the nail holes and any cracks, and paint the area.



Several architecture styles may include wooden eave brackets that could become deteriorated by a leaking roof. These at 417 Park Avenue are well maintained.

14.0 SITE FEATURES

Policy:

Preserve and retain historic site features of residential buildings, including landscaping. Ensure that new site and landscape features are compatible with the historic context of the building and area.

DESIGN GUIDELINES FOR SITE FEATURES

Fences and Walls

At residential properties, there may be a variety of fences and walls. Privacy fences, appropriate only for back yards, are typically of solid, wood construction. These are not historic features. Historic fences may include low fences encompassing the front yard and are of either wood or metal construction. They are inherently more visual and ornamental than restrictive and usually are not solid, having open space between slats or spokes. Retaining walls are low solid barriers installed to hold the grade and can be of poured concrete, brick or stone.

14.1 Retain and maintain historic fences and walls.

Properly care for original metal fences, and do not cover, remove or obscure them. Clean metals with the gentlest means possible to remove paint buildup and corrosion. If hand-scraping and wire brushing have proven ineffective, low pressure dry grit blasting (less than 100 pounds per square inch) may be appropriate as long as it does not damage the surface.



This picket fence at 112 Hilton Avenue is an appropriate style and height for a historic property.



This cast iron fence at 918 Jackson Street is well maintained and enhances the historic character of the property.

DESIGN GUIDELINES FOR SITE FEATURES, continued...

Wood fences are subject to exposure to rain. Monitor the condition of wood fences seasonally and keep them painted to reduce effects of the elements. Repair, or if necessary, replace individual pickets rather than replacing the entire fence. Repair masonry retaining walls using proper mortar mixes and compatible materials. Follow the guidelines for masonry.



Appropriate picket fence at 2010 N. 3rd Street.

14.2 New fences and walls should complement the historic character of their surroundings.

Construct new fences and walls with materials that were used historically or that visually match these materials. Wood or metal for new fences and stone for new walls are generally appropriate materials. Construct new wood and metal fences no more than three feet tall. Place pickets of a wood fence no more than three inches apart.

14.3 Install privacy fence of wood board or landscaping.

For back yard privacy, install wood fences up to six feet in height. Maintain the fence with regular painting. If a chain link fence is needed, locate it in the rear yard only, as to not be visible from the street. Apply green or dark paint or plastic coating to the chain link fence to minimize its visual impact. Alternatively install landscaping to obscure chain link fences. Natural fences may also be used as a privacy screen. Choose evergreen plants for year-round effect, and keep them well trimmed.



This privacy fence at 1908 Riverside Drive is of appropriate design and is painted green to blend in.



The newly installed wood fence at 1010 N. 2nd Street encloses the back yard, while a natural fence on the property line acts as a buffer with the adjacent property.



The natural fence of evergreen shrubs at 1706 Riverside Drive provides privacy and beautifies the property.

DESIGN GUIDELINES FOR SITE FEATURES, continued...

Ground Surfaces & Landscaping

14.4 Maintain historic placement, materials, and design for ground surface elements like walkways and drives.

Maintain original walkways and driveways. Repair these features in accordance with guidelines for masonry. Ensure compatibility between private ground walkways and drives and public sidewalks. Use materials with historic precedent.

14.5 Respect and preserve original grade and landscaping.

Do not alter the original terrain of a historic property. Retain plants and trees to perform passive solar energy functions like shading and wind breaks. Keep trees properly trimmed. When installing new landscaping, consider the mature size of selected plant stock.

Outbuildings

14.6 Preserve and maintain outbuildings.

Preserve and maintain original outbuildings such as garages and sheds as long as possible, following rehabilitation guidelines used for dwellings. Garages that are too small for modern vehicles should be adaptively reused for storage or other uses.

14.7 Design and locate new outbuildings carefully.

Design new outbuildings to be compatible with the architectural style of the associated dwelling. Site them at appropriate locations such as to the rear of a house or recessed back from the side elevations.



Brick walkway at 119 Glenmar Avenue.



The "ribbon" driveway design is a common historic design (400 Auburn Avenue).



Original garages at 1907 N. 3rd Street (left) and at 217 Hudson Lane (right) should be preserved.

DESIGN GUIDELINES FOR SITE FEATURES, continued...

Signs

14.8 Preserve, maintain, and repair historic signs.

Historic signs add to the overall appearance and character of historic commercial buildings; treat them as significant features of the property.

14.9 New signs should be simple and not detract from the associated structure.

Use signs of historically prevalent materials like finished wood, glass, iron, copper, or bronze. Use small signs with proportions that complement the building's. Home-occupation signs are limited to one square foot per the Zoning Ordinance. Keep designs and content simple. Limit colors to three that complement the building's color. Install signs in locations historically used for signs like on awnings, inside windows, projecting from the building façade, or standing in the yard. Do not obscure architectural features. Anchor mounting equipment in mortar, not bricks or stones. Limit signs to one per structure.



An example of an appropriate free-standing sign at 217 Hudson Lane.

Modern Conveniences

14.10 Place satellite dishes, garbage cans, fire escapes, and HVAC units out of view.

Use inconspicuous placement and the smallest size possible for dish antennae. Shield garbage containers, solar panels, external heating and air conditioning units, and utility meters from view using unobtrusive placement, landscaping, or a screen constructed to blend with the building. Locate window units on side or rear elevations.



The stairs at 903 N. 2nd Street are located on the rear of the building.



The HVAC unit at 903 N. 2nd Street is neatly screened (left). The satellite dish at 1005 S. Grand Street is appropriately located on a rear corner of the dwelling (right).

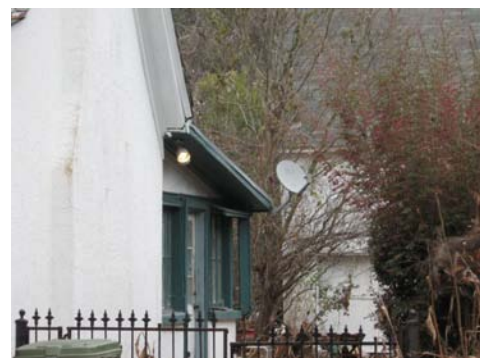

DESIGN GUIDELINES FOR SITE FEATURES, continued...

14.7 Locate solar devices and systems where they are unobtrusive and cause the least impact to the integrity of the historic building.

Rooftops, back yards, or rear accessory buildings that are out of public view are appropriate locations for solar devices. Side lots in a location that is not readily visible from the primary street are also options.

14.8 It is preferred that solar panels be located where they are the least visible from the street.

Rear elevations or rear roof slopes are the best location for solar devices. Solar panels should not be mounted on the facade of a building.

14.9 Ensure that solar panels that are attached to a building are not readily visible from the street.

Mount solar panels on rooftops flush with the roofline. If not attached to the building, locate solar panels in side or rear yards. Do not use hardware, frames, and piping with a non-reflective finish.

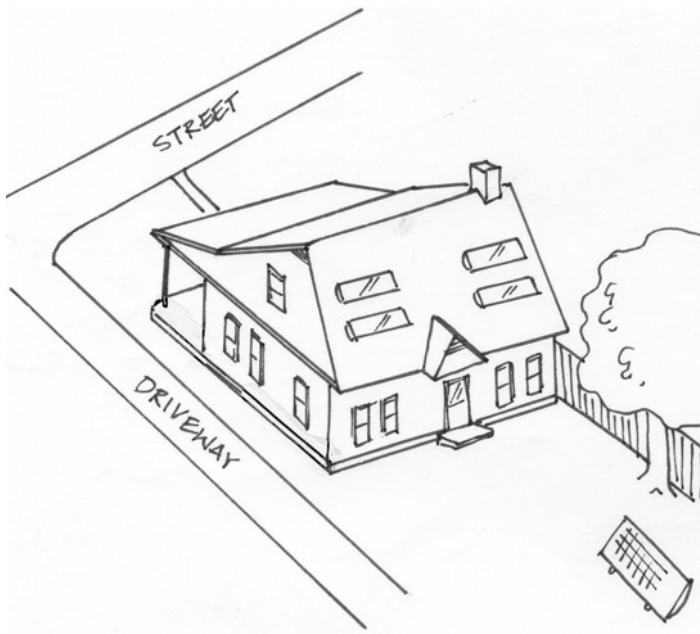

This sketch illustrates appropriate placement of solar panels behind the house.

DESIGN GUIDELINES FOR SITE FEATURES, continued...

14.10 Install ADA features with minimal effect to dwelling.

Follow all health and safety codes in such a manner that character-defining features and finishes are least effected. These features can also be screened to reduce their visual effect.



The elevator lift at 901 N. 3rd Street (above) and the ramp at 301 Hudson Lane (below) have minimal visual effects and are appropriately screened.



15.0 NEW ADDITIONS

Policy:

Design and construct new additions without radically changing, obscuring, or altering character-defining features of the historic building. Instead of attempting to create an exact copy of the original design, the new addition should complement the original historic building.

DESIGN GUIDELINES FOR NEW ADDITIONS

15.1 Consider location, size, and scale of the addition.

Do not overwhelm the historic dwelling with an over-sized addition. The window spacing and materials of the new addition should be compatible with those of the original building. Locate new additions on rear or side elevations where not visible from the street.

15.2 Retain historic character.

Consider the historic character of the original building, as well as of surrounding buildings in the district and choose a design for the new addition that will be compatible. Use contemporary design that can be clearly differentiated from the original building. The new addition should not duplicate form, material, style, wall plane, or roofline, but should fit into the original building as a distinct appendage. The new addition's design can reference motifs found in the original building.



New additions should be at the rear, smaller and subordinate to the historic building.



Decks are modern additions to historic dwellings and are appropriately located on the rear elevation, out of public view.

16.0 NEW CONSTRUCTION

Policy:

New construction of primary buildings should maintain the existing historic pattern of a neighborhood in terms of characteristics such as setback, distance between homes, scale, materials, and colors.

DESIGN GUIDELINES FOR NEW CONSTRUCTION

16.1 Maintain existing historic patterns.

Insure that new construction is compatible in setback, materials, height, width, scale, and proportions with historic buildings. The roof form of new buildings should also match.

16.2 Orientation towards the street.

New buildings must be oriented towards the major street.

16.3 Maintain existing patterns of building setback.

New buildings should be compatible with adjacent buildings in terms of setback.

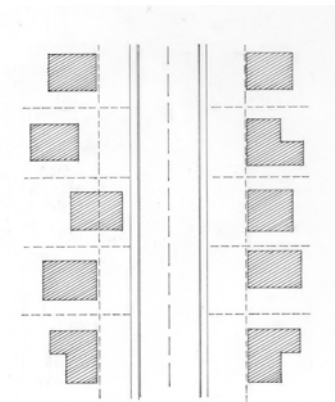
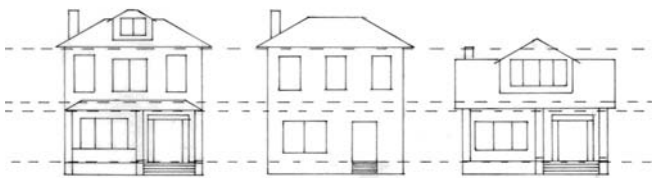

Above: These houses appropriately approximate each others' height and number of stories. Right: An overhead view shows that the middle building in the row on the left does not respect the existing pattern of setback.

16.0 NEW CONSTRUCTION

DESIGN GUIDELINES FOR NEW CONSTRUCTION

16.4 Maintain existing patterns of building height

New buildings should be compatible with adjacent buildings in terms of height.

16.5 Maintain existing scale along the street.

New buildings should be compatible with adjacent buildings in terms of scale and proportions.

16.6 Maintain existing patterns of roof form.

New buildings should be compatible with adjacent buildings in terms of roof form.

16.7 Match materials of surrounding buildings.

New buildings should be compatible with other buildings in the neighborhood in terms of materials.

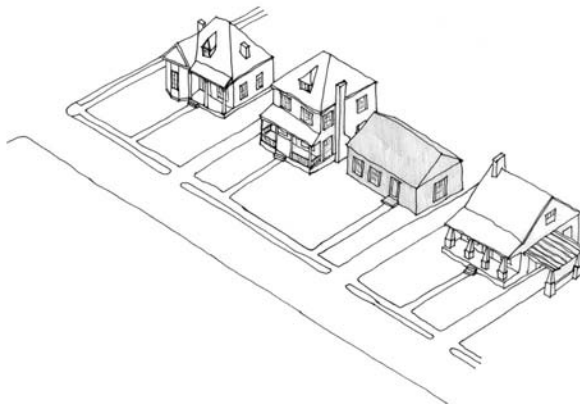

The infill building in the left sketch does not respect the existing pattern of building height. The infill building in the sketch on the right does not respect the scale and proportions of adjacent buildings.

COMMERCIAL BUILDING TYPES

Overview

Commercial buildings in Monroe can generally be defined by building types or by a specific architectural style or style influence. Building types can be categorized by features that shape the overall arrangement of the façade, such as form, massing, door and window openings. The primary façade generally faces the street and serves as the main entrance into the building. Building types may then be embellished to reflect architectural detailing and styles common from its construction period.

The most comprehensive study of commercial buildings is *The Buildings of Main Street, A Guide to American Commercial Architecture* by Richard Longstreth published in 1987. Longstreth's research resulted in the identification of eleven major building types that dominate the country's commercial architecture in the 19th and 20th centuries. Some of these building types are found in Monroe and also reflect a variety of architectural styles.

One-Part Commercial Blocks

Most commercial buildings in Monroe can be characterized as either One-Part or Two-Part building types. A One-Part commercial building is generally one-story in height and displays a storefront with transoms and display windows resting on bulkheads (the lower panels on which the windows rest).



A good example of a One-Part commercial block is the building at 103-105 Catalpa Street.

BUILDING TYPES, continued...

Two-Part Commercial Blocks

Monroe also has several commercial buildings that can be characterized in form as Two-Part commercial blocks. These are buildings that consist of two primary sections – storefronts and upper facades. Original storefronts are largely transparent and consist of display windows resting on bulkheads, transoms, and entrances with glass and wood doors. Upper facades have one or more floors of windows and decorative detailing such as brick, concrete or terra cotta panels and cornices at rooflines, which may be indicative of a particular architectural style. These buildings are generally no more than three-stories in height.

The buildings at 101 N. Grand Street (left) and at 404-408 Desiard Street (below) are representative of Monroe's Two-Part commercial blocks.



ARCHITECTURAL STYLES

Architectural Overview

Monroe contains a wide range of commercial architectural styles and designs. Historic commercial buildings in the city date from the late-nineteenth century through the mid-twentieth century and reflect the city's commercial growth and follow the stylistic designs of the period. Those built from ca. 1880 to ca. 1910 generally display the influences of the Italianate and Romanesque styles. These styles placed an emphasis on rounded arched windows, decorative cornices at the roofline and extensive decorative detailing on upper façades.

By the early 20th century, commercial buildings exhibited the influence of the Colonial Revival and Neoclassical styles. Buildings with Colonial Revival characteristics were generally built with rectangular rather than arched windows and with classical detailing such as Doric and Ionic pilasters, and cornices with dentils and modillion blocks. Neoclassical designs featured a dominant entrance and large classical columns typically with Ionic or Corinthian capitals.

Less elaborate commercial buildings built between 1900 and 1930 utilized the brick exterior itself for decorative flair. Called Tapestry Brick, this vernacular commercial style uses brick patterns and colors to bring architectural detailing to a building's façade. Often stone, concrete, or terra cotta might be added for accents. Additionally, the roofline might include a parapet.

ARCHITECTURAL STYLES, continued...

In the 1920s and 1930s commercial buildings generally became more restrained in their use of detailing and many buildings were designed with simple inset concrete or brick panels on the upper façade. New buildings followed the popular Art Deco and Art Moderne styles, which emphasized clean, sleek exteriors with a streamlined quality. Merchants in existing buildings recognized the importance of commercial marketing, and in the 1930s and 1940s, remodeled their storefronts with new materials such as tinted glass known as Carrara glass, copper and glass display windows, and recessed entrances with terrazzo floors. Since World War II, some of Monroe's commercial buildings have been remodeled with new storefronts and some upper facades have been concealed beneath false fronts. In some cases, changes to buildings that were made over fifty years ago can be architecturally or historically important, and in such cases are to be retained when the building is rehabilitated. Typical changes include the addition of Carrara glass in storefronts and terrazzo floor entrances, which gave the buildings a more modern appearance.



Downtown contains buildings with notable detailing such as the decorative metal design on the Post Office.

ARCHITECTURAL STYLES, continued...

Italianate, 1850-1890

This 19th-century architectural style emerged as a counterpoint to Classical sensibilities. It was inspired by the country villas of Italy and can be quite elaborate in decorative detail in its residential form. Its use in commercial buildings is more restricted by the uniformity of buildings within a street block. The influence of the Italianate style in commercial buildings can be found in decorative elements, especially windows with hood molding above. Embellished cornices and rooflines are also characteristic of the Italianate style. Also, the façade of an Italianate building may include cast iron pilasters on the first floor and brick on the upper floor.

Characteristics

- Windows with hood molding
- Paired or tripled windows
- Cast iron posts or pilasters
- Cornices with decorative brackets
- Pilasters dividing the façade into vertical bays
- False gables, finials, or other roofline decoration



The upper façade at 101 N. Grand Street shows the influence of the Italianate style with its elongated windows with hoods. The building also retains original cast iron columns and pilasters on the first floor.

ARCHITECTURAL STYLES, continued...

Colonial Revival, 1900-1955

The Colonial Revival style recalls the symmetrical and unadorned architecture of the nation's colonial period. A widely dominant style in American residential architecture throughout the first half of the 19th century, Colonial Revival designs were also prominent in commercial architecture. The style emphasizes symmetry and balance and employs classical detailing such as dentil molding. Pilasters are often utilized to divide storefronts into a balanced façade, and decorative embellishments, if present, are minimal.

Characteristics

- Symmetrical façade
- Rectangular sash windows
- Simple, unadorned cornice



Pilasters divide the façade at 130 N. 2nd Street and present a balanced and symmetrical appearance.

ARCHITECTURAL STYLES, continued...

Neoclassical, 1895-1950

Renewed interest in earlier Classical Revival and Greek Revival architectural styles led to the development of the Neoclassical style of the early 20th century. This interest was spurred by the architecture of the 1893 World's Columbian Exposition held in Chicago. The exposition promoted a classical theme and many of the country's leading architects designed large columned buildings which were placed around a central court. The exposition was a huge success, heavily attended and widely photographed and reported on across the country, thus making the Neoclassical style a fashionable trend. The large scale of the exposition's central building inspired numerous public and commercial buildings of similar designs across the country during the following decades.

Characteristics

- Large columns, typically with Ionic or Corinthian capitals
- Elaborate entrance, often with a pediment
- Rectangular, double-hung sash windows
- Dentil molding or modillions at the cornice



The bank building at 110 St. John Street exemplifies the Neoclassical style with prominent Ionic columns and pilasters supporting an elaborate pediment.

ARCHITECTURAL STYLES, continued...

Tapestry Brick, 1900-1930

This vernacular style can be considered a folk art, as the masonry exterior is the defining feature, rather than added decorative embellishment. The brick mason who lays the brick can incorporate design patterns and color into the exterior surface. The patterns are strongly geometrical, and the building façade is otherwise simple. Often the upper façade will feature inset rectangular panels, and the roofline may include a parapet wall of terra cotta or other accent material.

Characteristics

- Simple design
- Typically one-story
- Brick pattern and color adds decoration
- Stone, concrete, terra cotta may be added for accent



The buildings at 212 (left) and 310 N. Grand Street are examples of Tapestry Brick architecture.

ARCHITECTURAL STYLES, continued...

Modernistic, 1930-1960

Modernistic styles such as Art Moderne and Art Deco developed in the early- to mid-twentieth century and modeled the streamlined industrial designs of airplanes and automobiles. They feature smooth surfaces, curved corners, and horizontal emphasis to present a streamlined quality. The Art Deco style placed more emphasis on angularity and stylized floral and geometric designs. Neither the Art Moderne or Art Deco styles were utilized widely in Monroe for commercial buildings.

Characteristics

- Smooth wall surfaces
- Curved walls
- Limited ornamentation
- Glass block windows
- Horizontal emphasis
- Storefronts of aluminum, stainless steel, Cararra glass



The building at 111 N. 2nd Street (above) is an example of the Art Moderne style; The 1932 U.S. Post Office is an example of the Art Deco style (left).

1.0 STOREFRONTS

Policy:

Storefronts are especially important elements of commercial buildings that define the historic character and appearance of the building. Retain, maintain and repair historic storefronts and their components. Do not cover or conceal historic storefronts.

DESIGN GUIDELINES FOR STOREFRONTS

1.1 Retain and maintain historic storefronts and their components

Since they are at pedestrian level, storefronts are often the most visible feature of historic commercial buildings. Maintain storefront components, including display windows, bulkheads, transoms, doors, cornices, pillars and pilasters, with proper care and treatment. Do not cover or conceal these historic storefront components with modern materials.

1.2 Repair deteriorated or damaged storefronts or components so that the storefront retains its historic appearance.

If historic storefronts or their components are missing, replace them so that they replicate the historic storefront. Match replacement components to the original in size, material, texture, and detail. Use evidence such as historic photographs to help determine the design and style of missing components. Or use adjacent buildings as models.



Display window at 408 Desiard Street



The original storefront at 130 S. Grand Street features single-light glass and wood doors, transoms, and a large central display window.

DESIGN GUIDELINES FOR STOREFRONTS, continued...

Awnings

1.3 Select awnings of traditional design.

Awnings were common features on commercial buildings of the late nineteenth through mid-twentieth centuries. Shed awnings are most appropriate for commercial buildings in Monroe. Arched awnings are appropriate for arched openings. Canvas is an appropriate material for these type of awnings. Flat, metal awnings came into use on mid-century storefronts. Bubble, concave, or convex forms are discouraged except where used originally. Internally lit awnings and vinyl awnings are also inappropriate. Awnings may be retractable or fixed in place. Select awning colors that are compatible with and complementary to the building. Avoid harsh or overly bright colors.

1.4 Place awnings so that they do not cover or detract from architectural details and elements.

If pilasters or columns define the storefront, place awnings within these spaces rather than overlap the entire storefront. Upper façade windows are also appropriate locations for awnings. Do not install awnings that cover transom lights of prism glass or stained glass, as these are important visible features of a building.

1.5 Select awnings of traditional materials such as canvas and metal.

1.6 Do not place solar panels on awnings.

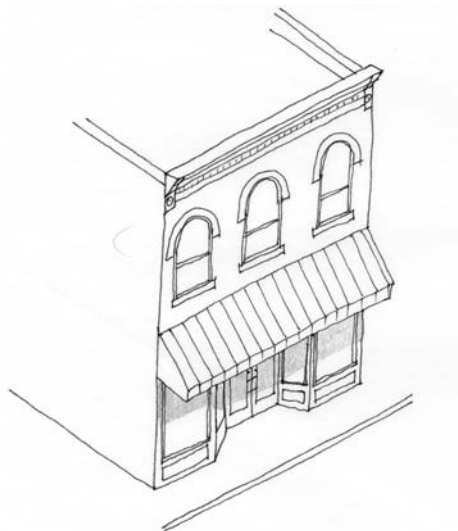

Awnings are appropriate for Monroe's historic storefronts and should be shed roof design and of canvas or similar materials.

DESIGN GUIDELINES FOR STOREFRONTS, continued...

Display Windows and Bulkheads

1.7 Preserve and maintain original display windows and bulkheads.

Display windows and bulkheads are significant components of traditional storefronts and are important to a commercial property's historic character and appearance. Repair rather than replace these original features.

1.8 Select replacement display windows and bulkheads that match the originals in location, design, size, and materials.

Replace missing or deteriorated original display windows or bulkheads with new ones to match the original. If the original is unknown, select replacement windows that are traditionally scaled with large glass lights and with as few structural divisions as possible to maintain the traditional transparent storefront look. If the original bulkhead material is unknown, replacement may be of wood, brick, metal, or other material that is appropriate with the façade.

1.9 Install proper framing and glass when repairing or replacing display windows.

Match window mullions or framing to the original; wood, copper, bronze metal, steel, or aluminum window mullions or framing is appropriate. Do not install tinted glass on a storefront unless it was used historically. Instead, use interior shades or blinds for privacy.



Tile bulkheads such as those at 406 Desiard Street (top) and 408 Desiard Street (bottom) are significant parts of storefronts from the early-to-mid-twentieth century.



Original frame bulkhead at 504 Desiard Street (left) and brick bulkhead at 117-121 Hall Street (right) should be maintained and preserved, not covered or concealed.

DESIGN GUIDELINES FOR STOREFRONTS, continued...

Doors and Entrances

1.10 Preserve and maintain original doors and entrances.

Retain and preserve original doors, surrounds, transoms, side-lights, unless they are deteriorated beyond repair. Original framing components such as jambs, sills, and headers of openings contribute to the entrance and should also be maintained. Preserve primary doors, or those on the main façade, as they are especially important to a building's historic appearance. Do not fill or partially block historic door openings.

1.11 Repairs to deteriorated or damaged historic doors should be consistent with historic materials.

When repairing historic doors, use methods to retain their historic fabric and appearance as much as possible. Epoxy may be used for strengthening and replacing deteriorated wood.

1.12 Replace historic doors that are beyond repair or missing with new doors that replicate the originals.

Replacement doors should match historic door in materials and size; ensure they are consistent for the style and period of the building. Ideally, the replacement doors will have the same series of panels and have a frame of the same dimensions. Historical evidence such as photographs are helpful in matching replacements to originals. If such evidence is unavailable, neighboring buildings of the same style and similar date of construction can be a guide for identifying appropriate doors. In replacing missing original doors,



Original doors should be preserved and maintained such as at 504 Desiard Street (above) and 131 N. 2nd Street (below).



The building at 233 S. Grand Street retains original six-panel doors.



DESIGN GUIDELINES FOR STOREFRONTS, continued...

select replacement doors that are similar in design to the original in style, materials, glazing (glass area) and lights (pane configuration).

1.13 Do not install new door openings where none existed.

Commercial buildings were designed with form-to-function principles, and their original openings should be sufficient for modern access. Installing new door openings is not recommended. When new openings are permitted, ensure new doors are compatible in scale, size, proportion, placement, and style to historic openings. Do not locate new openings on the main façade.

Staircases and Steps

1.14 Retain original staircases and steps.

Staircases and steps that are original to a building are another historic component of the building and add to its historic character.

1.15 Make repairs with in kind materials.

Repair wood and concrete stairs with materials in kind. If tile was historically used, its use in repair work is appropriate.

1.16 The addition of handrails is allowed.

Historic stairs or steps that never had handrails may have wood or metal handrails added if they are compatible with the style and design of the building. New or replacement stairs or steps can be designed to include handrails that are simple in design and no larger than 1-1/2" in diameter. These handrails can be attached to existing historic staircases to meet code requirements.



Example of appropriate replacement door at 247 S. Grand Street.



The distinctive entrance of the U.S. Post office enhances the character of the Art Deco building.

DESIGN GUIDLEINES FOR STOREFRONTS, continued...

Lighting

1.17 Maintain historic light fixtures.

Historic light fixtures accentuate the historic character of a building; preserve extant fixtures. Repair, rather than replace, deteriorated or damaged historic light fixtures using methods that allow them to retain their historic appearance.

1.18 Repair or replace missing or severely damaged historic light fixtures with replacements that replicate the originals.

Use photographic or physical evidence to match original light fixture design. If no such evidence exists, a design that is compatible with the remaining character-defining feature's of the historic building is appropriate. Use modern, low-wattage bulbs.

1.19 Keep fixtures introduced to the exterior simple in design and appropriate to the character of the building

If modern light fixtures are needed to replace missing ones, or where light fixtures previously did not exist, ensure that they are unobtrusive, conceal the light source, and direct light toward the building.

1.20 Do not allow light fixtures to damage or obscure architectural features or other building elements.

When securing light fixtures, make sure they do not damage masonry, siding, or other historic materials. Lights should increase visibility without detracting from the building's historic character.

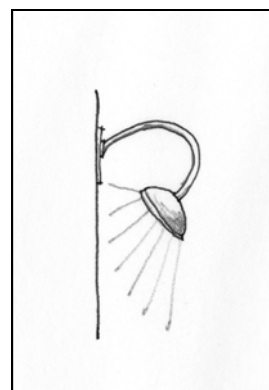
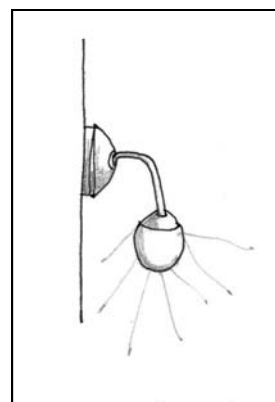
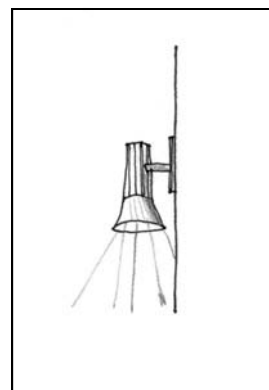

Examples of appropriate lighting fixtures.



Good reproduction light fixture at 130 S. Grand Street.

2.0 PRIMARY MATERIALS

Policy:

Preserve primary historic building materials, such as brick, wood siding, stone, or metal whenever possible. If historic materials are damaged, spot replacement can be achieved with material matching the original. Proper maintenance of historic primary materials is important; avoid harsh or abrasive cleaning treatments. Do not cover or conceal historic primary materials.

DESIGN GUIDELINES FOR PRIMARY MATERIALS

Brickwork and Masonry

2.1 Preserve and maintain original brick, stone, terra cotta, cast concrete, mortar, and other masonry original to a building.

Masonry helps define the historic character of buildings. Different textures, finishes, and patterns contribute to a building's distinct appearance. Preserve masonry, and do not cover or conceal original masonry surfaces with non-historic materials such as stucco, metal, adobe or vinyl.

2.2 When cleaning masonry, use the gentlest means possible.

Clean historic masonry only when necessary to halt deterioration or to remove graffiti and stains. Avoid any kind of harsh, abrasive cleaning such as sandblasting. The use of detergent cleansers to remove dirt or grime from masonry is acceptable. Use a diluted mild detergent and a soft brush with natural bristles, and/or a non-harmful chemical solution, followed by a low-pressure water rinse. When cleaning brick, it is advisable to test a small area first to ensure the procedure and cleaning agent will not damage the masonry. Never use a pressure-washer to clean or remove paint from masonry.

2.3 Keep historic masonry visible and unpainted.

Do not paint masonry that has never been painted. If water is penetrating historic masonry, water-repellent coatings can be used. Masonry naturally expands and contracts with temperature. Avoid silicone-based sealants on masonry walls, as they do not allow the brick to “breathe” and can trap moisture within walls.



Textured and tinted brick adds much of the character to this commercial building at 111 Catalpa Street.

DESIGN GUIDELINES FOR PRIMARY MATERIALS, continued...

Also, there are very good non-paint related treatments that are highly effective in strengthening damaged sandblasted masonry and rendering it more water repellant and resistant to the elements.

2.4 Avoid the use of power tools on historic masonry.

Hand tools allow for precision work and minimize the risk of damage to masonry. Power tools are damaging and are not appropriate when removing mortar.



Hard impermeable modern mortars may force moisture through the more permeable brick and force mechanical stresses to be relieved through the softer brick...

...which may lead to cracking, spalling, and erosion.

2.5 Preserve original mortar when feasible, but if repointing is necessary use mortar mixes similar to the original.

Soft mortar with a high ratio of lime was traditionally used in masonry buildings constructed prior to the 1930s. Relatively low proportions of Portland cement were used, if any. Harder mortars appear in more modern buildings. Match new mortar to the original mortar in width, depth, color, joint profile, and texture. When repointing historic mortar, it is important to use a mix that is softer and more permeable than the masonry units to ensure the preservation of the historic masonry.

Impermeable modern mortar can be inappropriate for repointing older brick and stone because they may force moisture to pass through the more permeable masonry rather than the mortar. Mechanical stresses cause expansion, contraction, settlement, and water-driven deterioration mechanisms like freeze-thaw will also be relieved in the masonry rather than the mortar if the latter is harder than the former. Modern mortars may also contain harmful soluble salts that further accelerate brick and stone deterioration.

DESIGN GUIDELINES FOR PRIMARY MATERIALS, continued...

Siding

2.6 Preserved and maintain original siding

Original siding material is a significant part of the fabric of a structure. It provides scale, texture, and shape, which help to define and characterize an architectural style. Loss of original siding can change the identity of a building in an adverse manner.

2.7 Repair original siding when necessary, and replace only if it is proven to be deteriorated beyond repair.

Regular maintenance of siding will ensure its longevity. Apply paint of an opaque stain to wood siding to provide a finished surface. If replacement of siding is necessary due to deterioration, match new siding to the original in size, placement, and design.

2.8 Synthetic or substitute materials such as vinyl, aluminum, and asbestos are not compatible materials to historic buildings built prior to about 1950, and are not allowed as replacement materials on these earlier historic buildings.

Synthetic sidings do not appropriately replicate traditional wood siding and greatly detract from a building's historic appearance. Do not replace traditional materials such as wood or brick with synthetic materials. However, these types of materials might be suitable for buildings constructed in more recent decades if the materials were used originally.

2.9 The use of cementitious siding materials may be approved. The installation of wood/cement exterior siding materials may be approved for new construction, additions, outbuildings or to replace deteriorated siding. If used to replace deteriorated siding, the siding should match the original wood siding in dimensions and profile. Only smooth cementitious siding should be used in the historic districts - the "grained" siding does not resemble wood siding.

2.10 Clean siding with the gentlest means possible.

Avoid potentially destructive, dangerous, and/or abrasive cleaning techniques, such as propane torching and sand- or water-blasting.

DESIGN GUIDELINES FOR PRIMARY MATERIALS, continued...

Cast Iron and Metal

2.10 Preserve and maintain cast iron and metal original to a building.

Metal components of commercial buildings help define a building's historic character. Properly care for original metal features, and do not cover, remove or obscure them.

2.11 Clean metal elements with the gentlest means possible and keep free of rust.

Soft metals such as bronze, lead, tin, and copper are easily damaged and should be cleaned with appropriate chemical methods; use the gentlest cleaning methods for cast iron, wrought iron and steel metals to remove paint buildup and corrosion. Hand-scraping and wire brushing are usually effective. However, if needed, low-pressure dry-grit blasting (less than 100 pounds per square inch) may be appropriate as long as it does not damage the surface. Test an area not readily visible, first.

2.12 Repair metal features by patching, splicing, or otherwise reinforcing the metal using recommended preservation methods.

For extensively deteriorated or missing parts, repair may also include limited replacement in kind or with compatible substitute materials. Use surviving examples or historic documentation for an accurate reconstruction of the original. Replicate missing elements with new metal to match the original as closely as possible in texture, profile, and appearance. In some situations, substitute materials such as aluminum, wood, plastics, and fiberglass, painted to match the metal, can be used. Check to be sure any substitute material is compatible with the original metal and there is no danger of a galvanic reaction.



Preserve and maintain original cast iron features such as those at 249 S. Grand Street (above) and 247 S. Grand Street (below).



Cast iron name plate at 247 S. Grand Street.

DESIGN GUIDELINES FOR PRIMARY MATERIALS, continued...

Tinted Glass, Marble and Stone Veneers, Concrete Panels, Porcelain and Aluminum

Beginning in the mid-twentieth century, office buildings and medical complexes became incorporated into commercial districts. During this period, several new materials came into use for commercial building facades. These included tinted glass, aluminum and stainless steel for display window surrounds, porcelain panels, concrete panels, and glass curtain walls. Some of these materials are no longer manufactured and pose challenges for repair and replication. Repair is always the preferred alternative. If repair is not feasible it is recommended that materials be used to match the original as closely as possible. There is a growing industry in salvaging and selling materials from this time period and if not available locally, seek materials from companies on the internet. Guidelines for these materials are as follows:

2.13 Preserve and maintain historic materials from the mid-twentieth century.

2.14 If repair is not an option, consult salvage companies or internet sources for replacement materials.

2.15 If exact replacement materials cannot be obtained, use materials that replicate the original as closely as possible in appearance, color and texture.

Paint

2.16 Maintain a building's original historic painted or unpainted appearance.

Maintain the painted surface of historically painted buildings or features. Do not paint masonry buildings that have not been previously painted.

2.17 Use non-abrasive methods to remove paint and protect historic materials during removal.

To remove paint, use non-abrasive methods such as chemical cleaning, hand-scraping, or hand-sanding. Do not use abrasive or high-pressure removal methods are destructive.



This 1950s building at 132 N. 2nd Street has an exterior of brick and steel casement windows.

3.0 WINDOWS

Policy:

Preserve, maintain or repair original windows. Do not conceal, enclose or cover historic windows. If replacements are necessary due to deterioration, match the historic window in size, and number and arrangement of panes, or lights. Ensure replacement window frames are of the same material, such as wood or metal, as original windows. Do not introduce new window openings on facades.



Original arched two-over-two wood sash windows at 101 N. Grand Street



Six-over-six wood sash windows at 117-121 Hall Street.



In addition to wood sash windows, buildings in downtown Monroe also were designed with fixed and casement steel windows. These types of windows are also important to defining the character of the buildings such as at 328 Desiard Street (top) and 130 N. 2nd Street (bottom).



One-over-one arched window with segmental arch above at 500 Desiard Street

DESIGN GUIDELINES FOR WINDOWS

Treatment of historic wood windows

3.1 Preserve and maintain original windows.

Window openings, windows, window details, and the size and shape of these elements help establish rhythm, scale and proportion of buildings and reflect architectural style and character

3.2 Repair deteriorating wood windows as needed. When possible, replace missing panes or damaged sashes rather than entire windows.

Retain as much of the historic window material and detail as possible to help preserve the building's historic character and appearance. Replace only those elements necessary. Use epoxy to strengthen deteriorated wood.

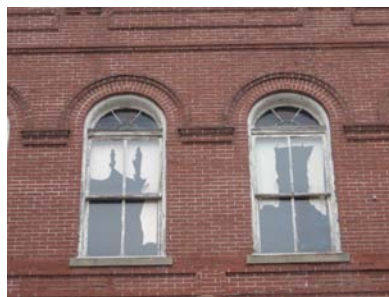

Preserve and maintain original windows such as at 125 St. John Street

Treatment of historic steel, aluminum, bronze and other metal windows

3.3 Preserve, maintain and repair original windows.

Metal windows such as steel, aluminum and bronze were introduced and widely used in the mid-twentieth century. Preserving these materials as well as their original designs and details is recommended. Make repairs with materials that match the original as closely as possible.

Metal windows are sometimes replaced due to concerns over energy conservation. Aluminum windows of the 1950s and 1960s were often installed with single glazing on large curtain walls, resulting in poor energy efficiency. Weatherstripping can improve the energy performance of metal windows. Spring-metal, vinyl strips, compressible foam tapes and sealant beads are other weather stripping options. A window's original single glazed glass may also be replaced with thermal glass panes (3/8" to 5/8" thick) provided that the rolled metal sections are at least 1" wide and the design of the historic window is retained. Another option for improving energy efficient is the installation of storm windows.



Original six-over-six and eight-over-eight wood windows at 404-408 Desiard Street. This window is significant to the design and character of the building.

It may be necessary to consult with a historic architect, architectural conservator, or experienced contractor to determine the appropriate treatment.

DESIGN GUIDELINES FOR WINDOWS, continued...

Replacement Windows

3.4 Replace windows only if they are beyond repair, and match replacements to the original in size, materials, and number and arrangement of lights.

Wood is the preferred material for wholesale window replacement, but other acceptable alternatives may be aluminum-clad wood or aluminum. Most major window manufacturers have appropriately sized wood windows for historic commercial buildings. Anodized or baked-on enamel aluminum in white or dark finishes is also appropriate; however, for multi-story buildings consider installing wood windows on the second story and baked or anodized aluminum windows on the third floor and above. Replace historic metal windows with like materials.



These one-over-one sash windows are a good example of replacement windows. They match the historical design and configuration of the original windows.

In addition to materials, the primary concern for replacement windows is matching the appearance of a historic wood or metal window through appropriate dimensions, depth of frame, and the appearance of true divided lights. True divided lights for windows are preferred or windows with lights that are bonded to the glass with spacers and appropriate grid profiles.

It is possible to consider alternative materials in some special cases, if the resulting appearance of the window will match that of the original in terms of design, finish of the material, and its proportions and profile.

Transoms

3.5 Preserve and maintain original transom glass and framing.

Transoms add distinct character and are important storefront elements. Repair transoms as necessary with materials that match the original.

3.6 Do not obscure transom lights.

Do not cover or conceal transoms with signs, the introduction of new materials, or other items. Awnings are allowable if they do not obscure transoms from complete view.



The original transom above the 1950s storefront at 117 Desiard Street is intact and not concealed.



The transom at 103-105 Catalpa Street could be uncovered as part the of building's restoration.

DESIGN GUIDELINES FOR WINDOWS, continued...

Storm Windows

3.7 Install storm windows and doors of appropriate material and design so as not to detract from the building's historic appearance.

Select storm windows and doors of wood, baked-on enamel or anodized aluminum, and ensure they fit within the window frames, not overlap the frames. Select storm windows of full-view design or with the central meeting rail at the same location as the historic window. Select storm doors of full-view or half-light design. Ensure they are compatible with the existing door and do not obscure or cover architectural features.

Security Doors and Windows

3.8 Security doors are most appropriate for rear and side elevations.

Entrances on facades are key focal points and visual elements of historic buildings, and security doors can detract from their historic appearance. Entrances on side and rear elevations are less visible and more appropriate for security doors and windows.

3.9 Install security doors and windows that are full-view design or have a central meeting rail that matches the historic door or window.

A full-view design allows the visibility of the historic door. Security doors with ornate or decorative grillwork obscure historic features and are not allowed on facades.

Security bars are more appropriate on side or rear elevations.



4.0 ARCHITECTURAL DETAILS

Policy:

Preserve and maintain historic architectural details and features, as they are important stylistic elements that help to define a building's character. Do not remove or conceal historic architectural details. If repair or replacement is necessary, match replacements to the original as closely as possible in material, design, color, and texture.

DESIGN GUIDELINES FOR ARCHITECTURAL DETAILS

4.1 Retain and maintain historic architectural details and features; do not cover or conceal them.

The style, character, and craftsmanship of historic architectural features convey a sense of the building's original period and setting. Preserving and maintaining these elements is important in retaining a building's historic integrity. Likewise, the removal or concealment of original architectural details diminishes a building's ability to its historical significance. Proper care and maintenance will help to ensure the longevity of architectural details and features.

4.2 Cleaning is warranted only for serious staining.

Clean architectural details and features only when necessary in order to extend their longevity. In general, water, mild detergent, and soft brushes are appropriate cleaning tools. For more complicated situations, consult with an architectural conservator, historic architect, or contractor with extensive experience working with historic buildings.

4.3 When repairing deteriorated or damaged historic architectural features, use the methods that allow them to retain their historic appearance and as much of the building's historic fabric as possible.

For decaying wood, apply epoxy to strengthen damaged areas and fill in small openings. For large areas of decay, cut away damaged areas and piece new wood into the gap. For lightly corroded metal features, remove rust and flaking paint with hand scraping or



Preserve and maintain architectural details such as the corbelled brick cornice at 125 St. John Street.

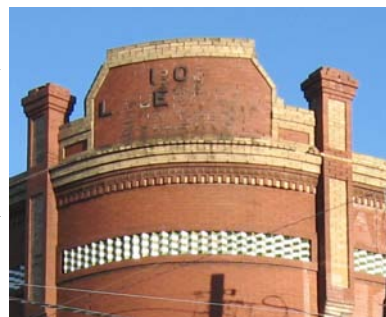

Architectural details exhibit craftsmanship and help convey a building's distinct character. This rounded corner parapet is at 500 Desiard Street

DESIGN GUIDELINES FOR ARCHITECTURAL DETAILS, continued...

chipping or use of a wire brush. For heavy corrosion, low-pressure grit or sand blasting, flame cleaning, or a mild chemical treatment may be appropriate. For their protection, cover adjacent materials such as brick, glass, and wood during grit blasting. Paint metal pieces immediately following rust and paint removal. Epoxies may be used to fill small gaps. It may be necessary to consult with a historic architect, architectural conservator, or experienced contractor to determine the appropriate treatment.

4.4 Do not add architectural features to buildings where none historically existed.

Architectural details and features are elements that are intended to attract attention and define the historic style and appearance of a building. Removing original features hinders a building's innate ability to convey its historic design and style. Introducing new elements will also compromise the building's historic integrity.

4.5 Replace missing or severely damaged historic architectural details and features with examples that replicate the original.

Match replacements to the original in design, proportion, and detail. Historical documentation such as photographs, drawings, graphics, or physical evidence are very useful in matching replacement elements to original ones. Where no such evidence exists, choose a simple design in keeping with the building's historic architectural style and period.



Architectural details at 200 N. 4th Street included brick corbelling and arched openings (left). Inset concrete design at the cornice at 212 N. Grand Street (above) are significant details to be preserved.

DESIGN GUIDELINES FOR ARCHITECTURAL DETAILS, continued...

Cornices

4.6 Preserve and maintain historic cornices.

Cornices are prominent decorative features of historic buildings and help to define their character. Do not remove, conceal or cover original cornices with modern materials.

4.7 Do not add cornices to a building if the building appears to have never had such a feature.

Adding elements to historic buildings that were not there originally detracts from the building's integrity.

4.8 When replacing a missing cornice, match the original in style, materials, size, and design.

In cases where original cornices are missing, rehabilitation may include installation of new cornices based on physical or pictorial evidence of the original design. Search local repositories for historic photographs of Monroe from the nineteenth and early twentieth centuries. However, if no historical, physical and/or pictorial evidence exists for a particular building, new cornices may be of a new design that is compatible in size, scale, and materials.



The fret band at 404-408 Desiard Street is an intricate design and would be difficult to replicate. This architectural detail is significant to the character of the building and should be preserved and maintained.

Monroe commercial buildings offer a wide variety of cornice styles and materials, each giving its building distinct character and identity.

top: A sheet metal cornice at 233 S. Grand Street.

center: A stone cornice at 328 Desiard Street.

bottom: A sheet metal cornice on the Judge Building at 100 S. Grand Street.

5.0 ROOFS

Policy:

Roofs help to determine building style and are important elements of historic appearance. Retain historic roof shapes. Limit public visibility of modern features.

DESIGN GUIDELINES FOR ROOFS

5.1 Retain historic roof shapes and features.

Preserve roofs in their original size, shape and pitch, with original features (such as cresting, finials, etc.). Retain and preserve roof features such as parapets, cornices, and chimney flues.

5.2 Do not introduce new roof elements that detract from the building's historic appearance and character.

Ensure new roof elements such as skylights, solar panels, decks, balconies, and satellite dishes are not readily visible from the street and do not obscure original features.

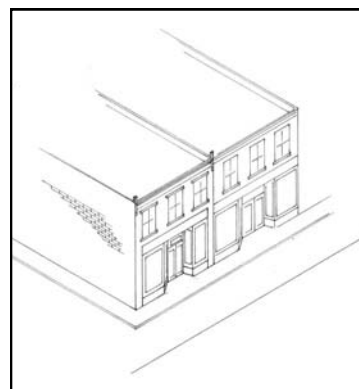

Most historic commercial buildings were designed with flat or sloping roofs.

Chimneys

5.3 Do not remove or alter original chimneys

Preserve original chimneys even if they are no longer functional architectural features. Do not cover chimneys with stucco or other veneers unless they were original. Concrete, slate, unglazed terra cotta and stone caps are appropriate.

5.4 Care for chimneys following the guidelines for brick-work/masonry.

When necessary use gentle cleaning methods. Use soft, historic mortar compounds that match the original when repointing.

5.5 If chimneys become unstable, rebuild the chimney matching the original as closely as possible.

Chimneys may be rebuilt or supported if they become unstable or damaged. Physical structural supports may include metal straps or brackets anchored to the roof framing. Match repairs to historic materials, shapes, mortar, material color, and brick patterns.

DESIGN GUIDELINES FOR ROOFS, continued...

Gutters and Downspouts

5.6 Install and maintain gutters, downspouts, and splash blocks.

Retain existing boxed or built-in gutters and keep them in good working order. Repair deteriorated or damaged gutters.

5.7 If original gutters are beyond repair, install replacement gutters of an appropriate type.

The most appropriate design for hanging gutters is half round. For buildings dating from or influenced by designs from the 1940s or later, ogee gutters are also appropriate.

5.8 Locate downspouts away from architectural features and on the least public elevation of the building.

Proper placement of downspouts will protect the building and not detract from its historic character. Ensure downspouts drain away from foundations and do not affect neighboring buildings.

Skylights

5.9 Preserve and maintain skylights that are original to a building.

5.10 Place skylights in inconspicuous areas where they will not detract from the historic appearance of the building.

Place added skylights on rear rooflines or behind gables, parapets, or dormers. Ensure skylights are not readily visible from the street.

5.11 Use appropriate skylight design.

When installing skylights, the most appropriate styles are those that lie flat or flush with the roofline. Convex or “bubble” designs are not recommended.

Skylights which are flush with the roof and not readily visible from the street are appropriate for commercial buildings.

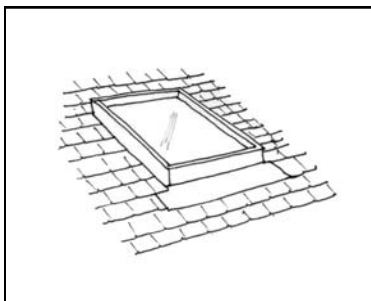

Monroe Design Review Guidelines

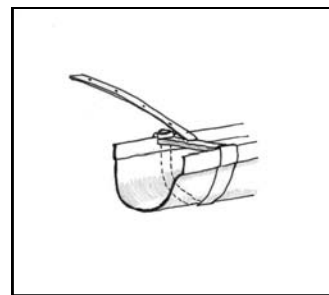

Half round gutters, as shown above, are the most appropriate for Monroe's historic buildings. Ogee gutters, below, may be acceptable for post-1940 structures.

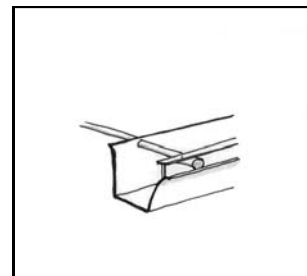

Appropriate rear gutter and downspout at 125 St. John Street.

6.0 FOUNDATIONS

Policy:

Foundations in Monroe are most often brick, stone, or concrete masonry walls. Preserve and maintain original foundation materials. Ensure foundations are repaired and maintained in keeping with masonry guidelines.

DESIGN GUIDELINES FOR FOUNDATIONS

6.1 Preserve and maintain original foundations.

Maintain original foundation materials, design and detailing. Do not cover original foundations with concrete block, plywood panels, corrugated metal, or wood shingles.

6.2 Follow masonry guidelines for cleaning, care, and repair of masonry foundations.

6.3 If replacement foundations are necessary, match the original as closely as possible.

Match replacement materials for foundations to the historic foundation and install using similar construction techniques.

6.4 Keep water away from foundations as much as possible.

Keep irrigation devices at least 3' away from foundations and direct all spray away. Also keep woody shrubs and trees away to prevent damage to historic materials. Ensure downspouts drain away from foundations through the use of splashblocks, drains, site grading etc.

7.0. SITE FEATURES

Policy:

Preserve and retain historic site features of commercial buildings, including landscaping. Ensure that new site and landscape features are compatible with the historic surroundings.

DESIGN GUIDELINES FOR SITE FEATURES

7.1 Preserve historically significant site features.

Preserve and maintain original site features such as fences and retaining walls in front of commercial buildings. Repair masonry retaining walls using proper mortar mixes and in kind materials.

7.2 Maintain street trees and landscaping.

Maintain street trees, sidewalks, walkways and planting strips for any private or public projects. Select plants that can tolerate the heat and pollution of city streets. Also consider maintenance requirements of landscaping and mature height of plant selections.

7.3 Respect and preserve original grading designs in front of commercial buildings.

7.4 Enhance commercial areas with streetscape elements.

Elements such as benches and planters make commercial areas more attractive and enjoyable.

7.5 Maintain a consistent historic character of the commercial area in major streetscape improvements considered in the future.

Ensure streetscape element designs is compatible in design and style with the surrounding streetscape and built environment.

7.6 Ensure that landscaping does not damage historic buildings or conceal historic elements.

7.7 Ensure that outdoor furniture is of uniform appearance and appropriate materials and not impede pedestrian flow.



Downtown's site features such as concrete benches and garbage receptacles are "hard edged" and are now dated in appearance. A new streetscape approach is recommended to provide for more contemporary designs. Retaining street trees and adding new planter boxes and landscaping is recommended. These features are in the 100 block of Desiard Street.

8.0 ADDITIONS

Policy:

When making additions to a historic building, select design, materials, and placement that minimize their impact on the historic appearance and character of the building and district. Ensure additions are compatible in size, scale, and design with the historic building.

DESIGN GUIDELINES FOR ADDITIONS

Rear Additions

8.1 Construct additions that are compatible with the original building in scale, proportion, rhythm, and materials.

The design of the addition should be in keeping with, and not detract from, the historic character of the building. Ensure elements such as roof pitch, materials, window design, window placement and rhythm, ratio of solids to voids, and general form of the addition are compatible with those of the original building. Make sure the addition does not disrupt successful drainage patterns to keep water away from historic materials.

8.2 Construct rear additions that are smaller and simpler in design than the historic building.

An addition should never match or overwhelm the historic building in size. Ensure its size and design complement the original building. Ensure rear additions are not readily visible from the street. The addition needs to be visually compatible but also distinguishable from the historic building. Subtle differences in materials or styles can help clarify new from original portions of the structure.

8.3 Construct rear additions that do not obscure or damage significant architectural features.

Protect cornices, architectural details, and other important features from loss of damage. Ensure additions cause minimal damage and do not cause removal of historic walls or roofs. Locate addition where existing openings can connect it to the original building.

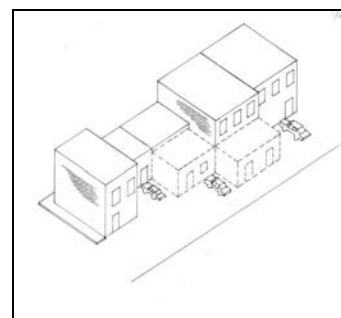

Shown is appropriate placement for ground level additions.

Rear elevations are best for additions to commercial properties.

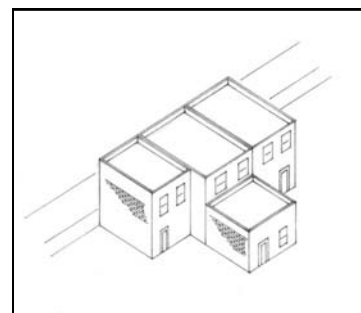

The location, scale, proportion, rhythm, materials, and size of this addition are all appropriate.

DESIGN GUIDELINES FOR ADDITIONS, continued...

Lateral Additions

8.4 Construct lateral additions that are compatible with the original building in scale, proportion, rhythm, and materials.

Ensure overall design of an addition is in keeping with the character of the historic building and will not detract from its historic character. Make sure elements such as roof pitch, materials, window design, window placement and rhythm, ratio of solids to voids, and general form of the addition complement those of the original building.

8.5 Construct lateral additions of mass and scale that are subordinate to that of the historic building.

Lateral additions should not draw attention away from the historic form and character of the original building. Lateral additions should be recessed from the front wall plane of the original building, never flush.

8.6 Design lateral additions so that they will not obscure or damage significant architectural features.

Protect cornices, architectural details, and other character-defining features from damage or loss. Ensure additions do not cause removal of historic walls or roofs. Use existing openings to connect the building and the addition. Ensure that new drainage patterns do not cause deterioration of historic materials.

8.7 Construct additions that are distinguishable from the historic building and be a product of their own time.

Ensure additions are visually compatible with the historic building, but also reflect their own era through subtle differences in materials and/or styles. Nuances in materials or styles can help differentiate new from original sections of the structure. Construct additions to be subordinate to the overall building. Ensure their size and design complement and do not overwhelm the building.

Roofline Additions

8.8 Construct rooftop additions of mass and scale that are subordinate to that of the historic building.

Construct rooftop additions to be smaller and simpler in design than the historic building. Ensure upper story additions do not overhang the lower floors.

DESIGN GUIDELINES FOR ADDITIONS, continued...

8.9 Construct rooftop additions with similar roof forms to the buildings to which they are attached.

Mimic the roof form of original building in the addition. For example, if the original building has a flat roof, then make the addition's roof flat as well.

8.10 Do not allow additions to cause the removal of character-defining materials and features.

Ensure the addition's design and placement do not obscure or damage significant architectural features including cornices and parapets.

8.11 Construct rooftop additions that are recessed and not readily visible from the street.

Maintain the original profile of the historic building. Preserve the mass and scale of the original façade; do not allow the rooftop addition to overwhelm the original façade. Ensure rooftop additions are not readily visible from the street level.

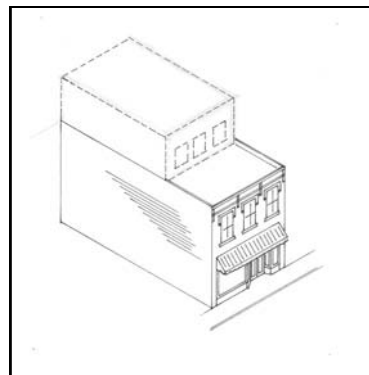

Recess rooftop additions so that they are not readily visible from the street. Mimic roof forms of the main building in the addition.

Decks

8.12 Locate decks where they are not visible from the street.

Locate decks on the rear elevations of buildings. They may also be located on a side elevation if screened from view from the street via fencing or plants. Another option is to locate a new deck on the roof as long as it is screened from view through either placement or existing roof parapets.

8.13 Keep decks design simple.

In order not to detract from the historic architecture, keep decks simple in design. Space wood balusters less than three inches apart.

8.14 Construct decks of materials similar to those used on historic buildings, however decks of alternative materials may also be acceptable if not readily visible from the street.

8.15 Stain or paint decks in colors that are compatible with those of the building.



Rear decks of wood construction are appropriate on rear elevations not readily visible from the street (132 N. Grand Street).

9.0 ACCESSIBILITY

Policy:

Ensure that primary entrances to commercial buildings meet ADA requirements. If this is not possible, make alternative entrances available, clearly mark them and maintain them to the same guidelines as the primary entrance. If access ramps are needed, simple designs compatible with the building's historic character are recommended for main entrances.

The Americans with Disabilities Act (ADA) was passed in 1990 and requires that all places of public accommodation be accessible to everyone. Historic commercial buildings must meet ADA requirements. Local and state codes apply as well. Property owners need to consult the Americans with Disability Act Accessibility Guidelines (ADAAG) when complying with ADA requirements. State and local requirements, however, may differ from the ADA requirements, and property owners need to be aware of all applicable accessibility requirements before making any modifications to their buildings.

Compliance with ADA, however, does not mean that the historic integrity of a building has to be compromised. Property owners can provide accessibility without compromising significant features or overall character of their historic property. Creative solutions include incorporating ramps, installing wheelchair lifts, creating new entrances, and modifying doors, hardware, and thresholds. In addition, alternative measures can be considered if there is a threat to the historic resource. If at all possible, maintain access to a historic buildings through a primary public entrance. If this cannot be done without causing permanent damage to significant features of the building, then make a secondary public entrance accessible. In these instances, provide directional signs to the accessible entrance. Avoid using rear or service entrances as the only accessible entrance.



Push plates for ADA access are appropriate solutions for access into commercial buildings.

DESIGN GUIDELINES FOR ACCESSIBILITY

9.1 Accessibility solutions must meet all state and local accessibility requirements as well as ADA mandates.

The steepest allowable slope for a ramp is usually 1:12 (8%), but gentler slopes are better when possible. Most codes will allow a slightly steeper ramp for historic buildings to overcome one step. Ramp landings need to be large enough to accommodate wheelchairs, typically a minimum of 5' x 5'.

9.2 Provide accessibility solutions of the highest level of access and the least impact on the building's historic character.

Identify and evaluate accessibility options within a preservation context. Avoid damage to significant features and materials .

9.3 Locate access ramps where they will have the least visual impact on the building's historic character.

Installation of permanent ramps is one of the most common solution to accessibility issues. Ensure the design and location of ramps are such that they do not compromise a building's historic character.

9.4 Keep access ramps simple in design.

Simple designs are best with railings distinguishable from historic features. A variety of materials, including wood, metal, brick and stone, are appropriate to face the ramps. For ramp construction do not use unpainted pressure-treated wood, which has a temporary appearance and is not visually compatible with most historic properties.

9.5 Avoid use of temporary ramps.

Temporary or portable ramps of light-weight materials are often unsafe and are not visually compatible with historic buildings. While not recommended as a permanent element, temporary ramps may be used as an interim solution until a permanent solution is achieved.

9.6 If historic doors do not allow for universal access, retrofit replacement doors to meet guidelines.

The use of automatic door openers with push plates is also an alternative to meet ADA door requirements on commercial buildings. When retrofitting doors to allow accessibility, maintain historic doors; do not widen door frames on facades. If historic doors

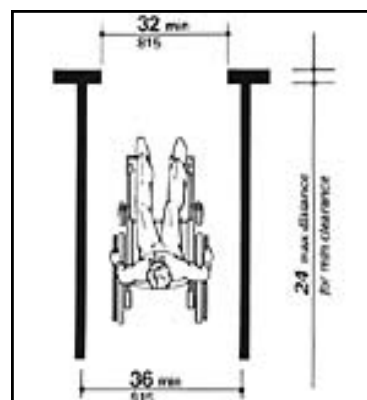

Make new entrances or retrofitted doors a minimum of 32 inches in width to meet ADA guidelines.



Doors can also be modified with pressurized door openers to allow for ease of access.

DESIGN GUIDELINES FOR ACCESSIBILITY, continued...

are missing, widening the entrance is a possibility. Typical guidelines require a minimum of a 32" clear opening with manageable door opening pressures. Ideally, retain and upgrade historic doors with a device to reduce door pressure.

Fire Escapes

9.7 Retain original fire escapes when possible.

Retain original fire escapes and keep them in good working order. Repair is preferable to replacement of a historic fire escape. If repair is not possible, replace a fire escape in kind as closely as possible.

9.8 Locate fire escapes on rear elevations or otherwise located so they are not visible from the street.

Fire escapes are important safety features as a means of escape from upper floors. Fire escapes traditionally are located on the rear or side elevations of buildings; site fire escapes that are added to historic buildings in these locations where they will not be readily visible.

9.9 Ensure that the addition of fire escapes does not damage historic architectural features. Ensure construction of fire escapes does not damage historic features of the building.

9.10 Fire escapes may be either open or enclosed.

For enclosed fire escape surfaces, select materials matching or compatible with those used on the historic building. For open fire escape surfaces, use metal or alternative materials.



Fire escape at 132 N. 2nd Street



Fire escape at 125 St. John Street

10.0 SIGNAGE

Policy:

Retain and maintain existing historic signs if possible. Ensure new signs and significant alterations to existing signs are compatible with the historic building and streetscape. Install signs in such a manner that no damage occurs to historic materials. All signs must meet the specific requirements of any existing or future citywide sign ordinances.

DESIGN GUIDELINES FOR SIGNS

10.1 Preserve, maintain, and repair historic signs.

Historic signs add to the overall appearance and character of historic commercial buildings; treat them as significant features of the property.

10.2 Retain historic painted wall signs and "ghost" signs.

Leave painted wall signs on a building facade intact; do not paint over or remove them.



This mid-twentieth century, metal sign at 103-105 Catalpa Street incorporates neon lighting on its exterior, to outline lettering. This was a common style for the period.

DESIGN CONSIDERATIONS FOR NEW SIGNS

Basic Approach

These design guidelines apply to new construction and rehabilitation. Signs should be designed and installed in accordance with the City's Zoning Ordinance. Whenever there is a conflict between the regulations of the base zoning district and these design guidelines, the more restrictive apply. All new signage should be designed with the overall existing and historic context of a building and neighborhood in mind. Buildings with multiple tenants should have a master sign plan.

DESIGN GUIDELINES FOR SIGNS, continued...

NEW SIGNS FOR HISTORIC BUILDINGS

Number and Location

Signs may be located in a variety of places on buildings, including storefront beltcourses, façade walls, side walls, or on awnings or canopies. Signs may hang or be mounted in windows, or project from the face of the building. Signs may also be attached to windows or the glass areas of doors. Freestanding signs may be placed on the building site. Be sure that signs do not block pedestrian traffic or the visibility of motorists. Mounting hardware for signs should be attached to mortar, not masonry.

Signage should not dominate the building visually, so signs should not exceed 20% of the overall wall surface, not counting signs attached on transparent glazed surfaces of windows and doors.



This drawing shows traditional locations for commercial signage.

DESIGN GUIDELINES FOR SIGNS, continued...

New signs for historic buildings

10.4 Signs based on documented historic appearance are encouraged.

Historic photographs exist for many commercial buildings in Monroe and property owners and merchants are encouraged to refer to these photographs when designing signs for their buildings.



Example of an appropriate projecting sign at 122 N. Grand Street.

10.5 Use traditional materials for new signs.

Construct new signs out of materials such as wood and glass, and metals such as copper, bronze or aluminum. Ensure metal signs have matte or subdued finishes. Sandblasted wood signs are appropriate. The use of plastic, neon, or applied letters may be appropriate for mid-twentieth century storefronts.

10.6 Keep signs sized in proportion to the building.

Avoid oversized signs as they detract from the building's historic architecture.



Signs painted on windows, such as this one at 131 N. 2nd Street, are appropriate.

10.7 Coordinate sign colors with overall building colors.

10.8 Signs that resemble logos or symbols for businesses are encouraged.



Good local examples of projecting signs at 124 S. Grand Street and 200 N. 4th Street

DESIGN GUIDELINES FOR SIGNS, continued...

10.9 Ensure building signage maintains the historic character of the building, and does not have a negative effect on surrounding properties.

Too many signs on a historic property can be visually distracting, overwhelm the appearance of the property and streetscape.

10.10 Use traditional lettering styles for signs.

Serif, Sans Serif or Script lettering are appropriate. Do not allow letters to exceed 18 inches in height or cover more than 60% of the total sign area.

Signs for new construction and adaptive re-use

10.11 Place signs in traditional locations.

Traditional sign locations include storefront beltcourses, upper façade walls (not to exceed 20% of the overall wall surface), hanging or mounted inside windows, or projecting from the face of the building. Movable a-frame signs or “menu easels” provide additional signage for businesses and may be allowed.

10.12 Install signs that do not damage historic fabric.

Install signs in such a way that there is no damage to historic materials. Anchor mounting brackets and hardware for signs into mortar, not masonry.



A wall sign as at 212 N. Grand Street is one of several traditional placements for a new sign.

Signs for commercial buildings/offices in residential neighborhoods

10.13 Ensure signage reinforces the historic character of the building and district.

Monroe's residential historic districts contain corner commercial buildings and house stores. Businesses occupying these buildings included grocery stores, drug stores, hardware stores and other small, locally-owned shops serving nearby residents. Ensure signs for these buildings are in keeping with their architectural and historical character.

DESIGN GUIDELINES FOR SIGNS, continued...

10.14 Consider historic locations such as sign panels and cornices first when adding signage.

Commercial buildings in residential areas were often designed with areas intended for signage such as a sign band or panel below the cornice on the main façade. Consider these areas first when locating signage on the building.

10.15 Do not allow signs to obscure or conceal architectural features.

10.16 Appropriate sign types are flat signs, wall signs, projecting signs, awning signs and window signs.

While flat, wall or painted signs in traditional locations are encouraged, other historically correct sign types are also allowed.

10.17 Install signs that are non-illuminated or indirectly illuminated.

Ensure lighting for signs on commercial buildings are unobtrusive, indirect and compatible with the historic character of the building.

10.18 Ensure signs are integrated with and harmonious to the building and site, including landscaping which they may occupy.



Appropriate example of a freestanding sign in a formerly residential area at 909 N. 3rd Street. This sign is correctly sized and of appropriate materials.

DESIGN GUIDELINES FOR SIGNS, continued...

Signs for adaptively re-used buildings

10.19 Ensure residential buildings adapted for commercial or office use have signs that respect the building's original character.

Many buildings constructed as residences in Monroe's historic districts have been adapted for commercial and office use. The primary requirement for signage of these buildings is to maintain the historic residential character of the building and not have a negative affect on the surrounding residential properties.

10.20 Locate signs on the building itself, or as close to the building as possible for freestanding signs.

Signs for residential buildings may include letters along a fascia board above the entrance, wall signs adjacent to the main entrance or freestanding signs in front yards.

10.21 One sign per building may be allowed.

Window signs will not count toward the single sign maximum.

10.22 Install signs that are either non-illuminated or indirectly illuminated within a discreet light source, such as in-ground or hidden lighting.

Use and re-use of mid-twentieth century signs

10.23 The use and reuse of original neon, illuminated and internally lit mid-twentieth century signs is appropriate.

Monroe's historic districts contain commercial buildings constructed in the 1940s and 1950s and many of these retain original signs. Property owners are encouraged to preserve or repair these signs and adaptively reuse them whenever possible



The neon sign at 103-105 Catalpa Street contributes to the historic character of the building and should be repaired and preserved.

11.0 MECHANICAL EQUIPMENT

Policy:

Mechanical equipment and service utility devices should be sited where they are not readily visible. They should be placed in inconspicuous areas and be as unobtrusive as possible and screened with landscaping or fencing. If affixed to a building, devices should be installed to avoid damaging the property. Conduits should be painted to blend with the color of the building.



This roof mechanical system is set back so that it is not readily visible from the street.

DESIGN GUIDELINES FOR MECHANICAL EQUIPMENT

Utilities

11.1 Locate ground-mounted mechanical systems behind or on top of buildings.

If on the ground, screen them from view using fencing or plants. If on top of buildings, set them back or behind a parapet, not visible from the street. Add screening to assist in dampening the noise from mechanical systems, particularly in residential areas.

11.2 Locate window-mounted mechanical systems on the side or rear elevations; their visibility should be as minimal as possible.

11.3 Locate meters, conduits, and other equipment on rear elevations.

Trash and Recycling Storage Areas

11.4 Place garbage containers behind buildings and screen them from view.

Conceal dumpsters and other garbage containers with fencing or plants. In residential areas, locate these to have a minimal impact on adjacent residences.



These meters are correctly placed on a non-primary elevation.



This HVAC system at 211 Desiard Street is situated on the rear elevation.

MECHANICAL EQUIPMENT, continued...

Satellite Dishes

11.5 Install satellite dishes in inconspicuous areas where they are not readily visible from the street.

Locate them on the rear elevation or rear roof slopes and do not mount them on primary elevations of a building.

11.6 Satellite dishes that are small in size are more appropriate than larger ones.

Solar Devices and Systems

11.7 Locate solar devices and systems where they are least visible and obtrusive and cause the least impact to the integrity of the historic building.

Rooftops, rear lots or rear accessory buildings that are not readily visible from public right-of-ways (except alleys), if available, are the preferred locations for solar devices. Side lots in a location that is not readily visible from the primary street are also options. If readily visible, solar panels are most appropriate when placed in roof lines.

11.8 It is preferred that solar panels be located where they are the least visible from the street.

Rear elevations or rear roof slopes are the best location for solar devices. Solar panels should not be mounted on the facade of a building.

11.9 Ensure that solar panels that are attached to a building are not readily visible from the street.

Mount solar panels on rooftops flush with the roofline or hidden behind cornices or parapet walls. If not attached to the building, locate solar panels in side or rear yards. Do not use hardware, frames, and piping with a non-reflective finish.



Rooftops are the preferred location for solar panels.

12.0 NEW COMMERCIAL CONSTRUCTION

Policy:

New construction in Monroe’s commercial areas should be compatible with adjacent buildings primarily in scale, mass, and height, and secondarily in materials, orientation, shape, placement, and rhythm and proportion of openings. Do not attempt to replicate historic examples in architecture of a newly constructed building, but allow it to stand as a product of its own time while being compatible with the surrounding historic built environment.

DESIGN CONSIDERATIONS

Basic Approach

Where historic buildings have been lost or where there are vacant lots, new construction is encouraged to add to the streetscape and promote economic development within historic districts. While constructing a new building within a historic district can be a challenge, careful thought and planning can result in a design that is compatible with the historic surroundings.

The fundamental underlying concept in designing new buildings for historic districts is that the new building must be both compatible with the historic character of the district and be a product of its own time, or in other words not replicate historic designs. It is a common misconception that newly constructed buildings should look “old” and should imitate historic structures. It is important to realize that while historic districts do convey a sense of time and place associated with their history, these areas are not frozen in time and continue to be dynamic evolving communities. This evolution is made discernable via building styles and methods of construction that reflect the apparent age of the buildings.

The collection of original buildings from a district’s historic period conveys the district’s sense of historic time and place. And, it is important that new buildings constructed within a district reflect their own time to allow the evolution of the street to be ap-

NEW COMMERCIAL CONSTRUCTION, continued...

parent. Imitation of historic architectural styles is discouraged because it makes it more difficult to distinguish older historic buildings from newer ones and can make interpretation of the neighborhood confusing.

At the same time, designs for new construction should not seek to heavily contrast with the existing built environment. Designs that are meant to conflict with the older buildings simply for the sake of being different are discouraged. Instead, designs for new buildings should strive to be compatible with the historic surroundings.

New construction within a historic district should reinforce the basic visual characteristics of the surrounding area. Designs for new buildings can accomplish this by incorporating the fundamental design elements of historic structures with contemporary stylistic trends. New designs should draw upon fundamental building features that define the individual character of the given district. These include how buildings are located on their sites, how buildings in the district relate to the street and basic mass, form, and materials of historic buildings within the district. If new buildings employ these design variables in a manner similar to historic buildings in the district, then the new building will be visually compatible with its surroundings.

If new designs adhere to existing basic design relationships and fundamental similarities within a district, they can be compatible with the historic context of the district while also being distinguishable as of their own time. Modern interpretations of traditional designs are appropriate for new buildings as long as they are stylistically distinguishable from historic buildings. It is common in the City to have isolated commercial buildings within residential neighborhoods. New construction should be in keeping with the size, scale and materials of the historic residential and commercial buildings on the block and contribute to the overall sense of cohesiveness and continuity along the street.

DESIGN GUIDELINES FOR NEW COMMERCIAL CONSTRUCTION

SITE DESIGN GUIDELINES

Street Patterns

12.1 Respect historic patterns of building development.

Situate new buildings on their sites in a similar manner to surrounding historic buildings in the area.

12.2 Preserve historic street patterns.

Most historic areas of Monroe developed in traditional grid patterns. Ensure new construction within historic districts does not interfere with historic street or alley patterns.

Building Orientation

12.3 Orient new construction toward the major street.

Traditionally primary entrances are oriented to the street, which encourages pedestrian traffic. Orient new buildings toward the street to be consistent with the character of the streetscape.

12.4 Create a continuous façade wall through setback of new buildings in line with existing buildings.

Maintain the traditional lines that have been established along the street to create an even flow of buildings.

12.5 New construction should respect uniform setbacks along a block.

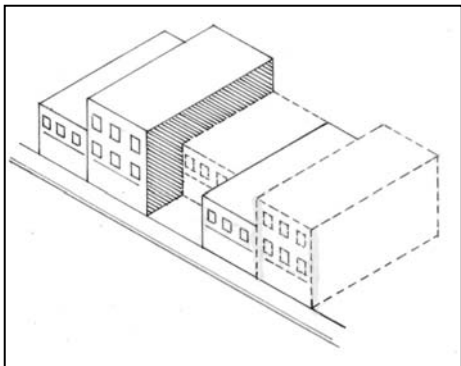

On the left, inappropriate new construction. On the right is shown appropriate new construction with uniform setback to create a continuous wall of facades.

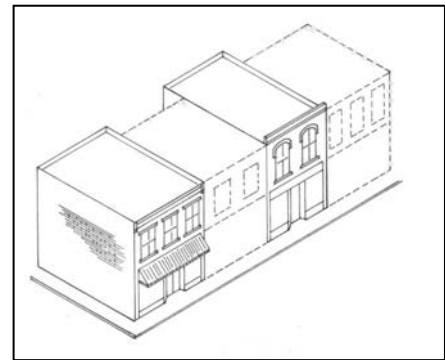

DESIGN GUIDELINES FOR NEW COMMERCIAL CONSTRUCTION, continued...

Street Lighting

12.6 Keep street lighting simple in design and unobtrusive.
Ensure lighting does not visually dominate the site or detract from the architectural character of surrounding buildings

12.7 Keep street light design compatible with the surrounding streetscape.
In residential areas, this may mean very subtle or minimal lighting.

12.8 Replicas of historic street lamp designs are not allowed.
Avoid replicas, as they invoke a false sense of history. Contemporary designs based on traditional styles may be approved.



Above is an example of an appropriate exterior pole light .

Surface Parking

12.9 Protect historic buildings and structures when planning and constructing parking lots.

12.10 Place parking areas where they are least visually obtrusive.
Behind buildings is the best choice for parking areas if feasible.

12.11 Screen new parking areas with landscape materials.
Screen new parking areas through the use of landscape materials such as shrubs, walls, or trees. Ensure these landscape materials have the same setback and location as the front walls of adjacent buildings. Divide large parking areas with plantings.

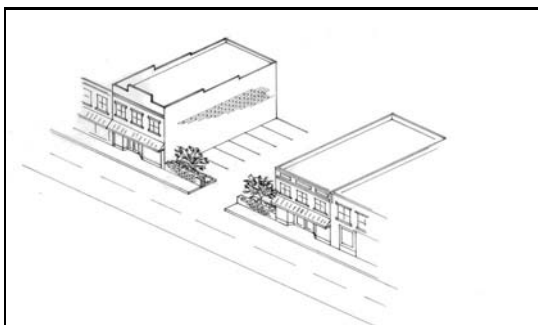

Parking lots should be screened with landscaping.



DESIGN GUIDELINES FOR NEW COMMERCIAL CONSTRUCTION, continued...

Parking Garages in Commercial Districts

12.12 Construct parking garages of design compatible with adjacent historic buildings.

Design new parking garages to be compatible with adjacent historic buildings in materials, fenestration, massing, and scale.

12.13 Maintain the pedestrian streetscape at parking garages.

Where parking structures abut streets, retail or other uses along the ground level are strongly encouraged to maintain pedestrian interest and activity.

12.14 Screen parking decks.

Ensure building materials and design effectively and attractively obscure the view to the interior of all parking decks. Design garages so that the sloping circulation bays are internal to the building and not expressed in the exterior treatment of the building.

BUILDING SCALE GUIDELINES

Mass and Scale

12.15 Construct new buildings to be compatible with adjacent buildings in terms of scale and proportion.

Replicating the existing pattern established along the block will provide visual continuity and uniform scale.

12.16 Construct new buildings so they are not dramatically larger than historic buildings, as to not overwhelm the streetscape.

While new buildings may be larger than historic ones, ensure they do not compromise the visual continuity of the street. New buildings of a larger mass may be subdivided into smaller visual modules that are similar in size to historic structures in the area.

Height

12.17 Construct new buildings so their height is compatible with that of adjacent historic buildings.

There is a wide diversity of building heights in Monroe. Ensure new construction is compatible in height with the block and general surroundings on which it is sited.

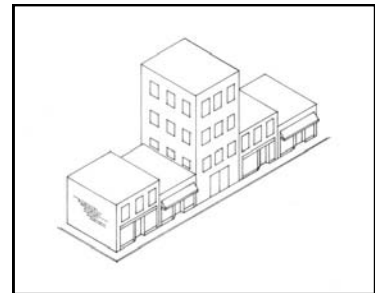

New buildings that are not compatible in height to surrounding historic buildings, such as shown in the image above, disrupt the sense of visual continuity along the street, and thus compromise the character of the streetscape.

DESIGN GUIDELINES FOR NEW COMMERCIAL CONSTRUCTION, continued...

Width

12.18 Construct new buildings to appear similar in width to surrounding historic buildings.

If new construction is filling a large footprint that is wider than traditional buildings along the block, divide the new construction into visually separate sections that give the appearance of traditional building widths. This can be accomplished with vertical divisions within the building design.



Large new buildings should be designed with vertical divisions to be consistent with traditional historic building widths.

Solid to Void Ratio

12.19 Ensure that window size and proportion of openings are consistent with adjacent historic buildings.

Design new to have similar amounts of wall space and openings for windows and doors as neighboring historic buildings. Create patterns in rhythm, size, and spacing of window and door openings similar to surrounding historic buildings.



Solid to void ratio: The top sketch at left illustrates new construction that maintains traditional solid to void ratio through appropriate number and size of windows. The bottom sketch illustrates inappropriate window size and placement.

DESIGN GUIDELINES FOR NEW COMMERCIAL CONSTRUCTION, continued...

BUILDING FORM

12.20 Construct new buildings of forms that are similar to those of existing historic buildings along the blocks on which they are sited.

Typically, commercial buildings in Monroe have been constructed in simple rectangular forms of varying heights.

12.21 Ensure the roof form of new commercial buildings match those of adjacent historic buildings.

Flat roofs are most common for commercial buildings in Monroe, but design new construction with roof forms consistent with surrounding buildings on the block.

12.22 Maintain the traditional separation between storefronts and upper facades.

Typically, ground floor storefronts are visually separated from upper floors through design patterns and window placement. Replicate this separation in new construction, and maintain the alignment with adjacent buildings.

Rhythm and Spacing

12.23 Ensure proportions of window and door openings are similar to those of surrounding historic buildings.

Similarity in rhythm and spacing of window and door openings strongly contributes to the visual appearance and character of a district. This includes the pattern of display windows along storefronts as well as upper level windows. It is important that new construction maintain a pattern similar to that already established in the district.

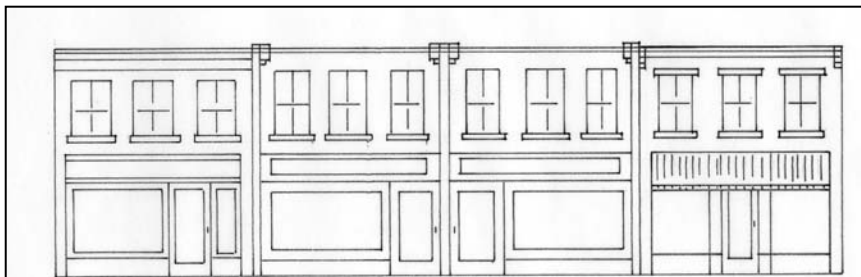

New construction should be consistent with storefront and window size and spacing.

Historic

NEW

Historic

DESIGN GUIDELINES FOR NEW COMMERCIAL CONSTRUCTION, continued...

BUILDING DETAILS

Materials

12.24 Use of traditional building materials that are compatible with adjacent buildings is preferred.

Common building materials such as wood, brick, and metal help to provide a sense of visual continuity and flow to the street. Alternative materials or combinations of materials will be considered on a case by case basis.

12.25 New materials that are similar in character to traditional materials may be acceptable with appropriate detailing.

Alternative materials may be approved if they appear similar in scale, proportion, texture and finish to materials used historically. Also, alternative materials must have a proven durability in Monroe's climate. Different materials may be appropriate for commercial areas with historic architecture from the recent past.

Architectural Character

12.26 Building components of new construction that are similar in size and shape to those found historically along the street are preferred.

Components such as windows, doors, bulkheads, and display windows of newly constructed commercial buildings that are comparable in size and shape to those of historic buildings in the area help to maintain visual continuity in the district.

12.27 The scale of decorative elements similar to that of surrounding historic examples is preferred.

These include ornamental elements such as cornices, moldings, or other decorative elements.

12.28 Construct new buildings to appear contemporary but compatible in design to historic buildings.

It is important to be able to distinguish new buildings from historic ones. Do not seek to replicate historic styles in new construction design, nor contrast dramatically with the existing historic architectural context. New buildings need to be visually compatible with neighboring historic buildings, yet be representa-



New construction such as illustrated above should have windows and storefronts in keeping with traditional designs and detailing.

DESIGN GUIDELINES FOR NEW COMMERCIAL CONSTRUCTION, continued...

tive of their own time. Visual compatibility is achieved through similarities in mass, scale, and established patterns of features such as windows, doors, and storefronts.

12.29 Contemporary interpretations of traditional details are encouraged.

For example, contemporary designs for window moldings and door surrounds can provide visual interest and convey that the construction is new.

12.30 The imitation of historic styles is discouraged.

Replication of historic styles makes it difficult to distinguish old and new buildings, and thus interpret the evolution of architecture within the district. Contemporary interpretations of historic styles may be considered if they are subtly distinguishable as new.

Windows

12.31 Windows similar in size and orientation with those in adjacent historic architecture are encouraged.

Traditionally upper story windows in Monroe's historic commercial buildings are rectangular in form with a vertical emphasis. Transoms, both rectangular and arched forms, are also common. In historic commercial buildings of the more recent past, a more horizontal emphasis or non-traditional window size and orientation may be present.

12.32 Use historic examples to design storefront display windows to reflect appropriate size, scale, and proportion.

Display windows are important character-defining features of commercial buildings, and similarity in scale will promote visual continuity of the streetscape.

12.33 Maintain traditional window shape.

Odd window shapes such as octagons, circles, diamonds, etc. are discouraged unless they are present in neighboring historic commercial buildings of the recent past.

DESIGN GUIDELINES FOR NEW COMMERCIAL CONSTRUCTION, continued...

Entries

12.34 Use historic examples to design appropriate entries in size, shape, and placement.

Monroe's historic commercial buildings have a wide variety of entrances, including recessed entries, central and corner entries, and both single and paired (double) doors. Similarity in entrances of new designs will promote a unified sense of scale and rhythm along the street.

Awnings and Canopies

12.35 Use traditional materials in awnings and canopies .

Cloth, canvas, or metal awnings or canopies are best for Monroe's commercial buildings. Vinyl or other synthetic materials are not allowed.

12.36 Install awnings that fit the opening(s) to which they are attached.

Use rectangular awnings for rectangular openings, and curved awnings for arched openings.

Lighting

12.37 Install subtle and unobtrusive exterior lighting.

Install light fixtures that are unobtrusive in design, materials, and placement.

12.38 Install fixtures that are compatible with the building and the streetscape and not be visually dominant or intrusive.

Ensure light design complements the new building's style and does not detract from the surrounding historic setting. Install lighting as a subtle addition to the property that does not dominate the overall site or intrude on adjacent properties.

12.39 Do not install light fixtures that suggest a false sense of history.

Contemporary interpretations of historic light fixture designs are appropriate; do not attempt to replicate fixtures of earlier architectural periods.

DESIGN GUIDELINES FOR NEW COMMERCIAL CONSTRUCTION, continued...

12.40 Lighting should be compatible and appropriate for the surrounding area.

Install light designs that complements the building while not detracting from the historic setting. For commercial buildings in residential neighborhood, lighting must have a minimal impact on surrounding residences.

Datestones/Cornerstones

12.41 Install datestones or cornerstones to identify new construction.

In order to help distinguish new construction from adjacent historic buildings, the addition of datestones or cornerstones displaying the building's date of construction is encouraged .

GLOSSARY

A. Procedural Definitions

Certificate of Appropriateness: A certificate issued by the Heritage Preservation Commission (HPC) to indicate approval of an application to alter the exterior appearance of a property located within a locally-designated historic district.

Process: The established procedures by which the various actions that may be taken by the HPC are carried out.

Public notice: Notice provided to interested parties before a commission takes action.

B. Technical Definitions

Adaptive Use: The reuse of a building or structure, usually for purposes different from the original use such as residence converted into offices.

Addition: New construction added to an existing building or structure.

Alteration: Work that effects the exterior appearance of a property including construction, reconstruction, repair, or removal of any building element.

Building: A structure with a roof, intended for shelter or enclosure such as a dwelling or garage.

Character: The qualities and attributes of a building, structure, site, street or district.

Configuration: The arrangement of elements and details on a building, structure or site which help to define its character.

Compatible: In harmony with surroundings generally in mass, scale, and height, and secondarily in materials, orientation, placement, and rhythm and proportion of openings.

Cultural Landscape: A geographic area that conveys a diverse representation of how human activity has changed and shaped the natural environment. Dominant features are topography, plant cover, buildings, or other structures and their patterns.

Context: The setting in which a historic element, site, building, structure, street, or district exists.

Demolition: Any act which destroys in whole or in part a building or structure.

Demolition by Neglect: The destruction of a building or structure through abandonment or lack of maintenance.

Design Guidelines: Design review criteria and methodology identified for the purposes of achieving alterations or development that is sensitive to and compatible with the building and/or context.

Element: A material part or detail of a site, structure, street, or district.

Elevation: A drawing of any one of the external vertical planes as in a facade of a building.

Fabric: The physical material of a building, structure, site or community, conveying an interweaving of component parts.

Facade: Any exterior side of a building or structure, especially the front or principal face that is typically given special architectural treatment.

Historic District: A geographically definable area with a significant concentration of buildings, structures, sites, spaces, or objects unified by past events, physical development, design, setting, materials, workmanship, sense of cohesiveness or related historical and aesthetic associations. The significance of a district may be recognized through listing in a local, state, or national landmarks register and may be protected legally through enactment of a local historic district ordinance administered by a historic district board or commission.

Historic Imitation: New construction or rehabilitation where elements or components mimic an architectural style but are not of the same historic period as the existing buildings (historic replica).

Heritage Preservation Commission: The City's governmental entity responsible for administering the criteria set forth in this document and the Monroe Zoning Ordinance as applies to locally-designated and historic districts.

Infill: New construction in historic districts on vacant lots or to replace existing buildings.

Maintain: To keep in an existing state of preservation or repair.

New construction: Construction which is characterized by the introduction of new elements, sites, buildings, or structures or additions to existing buildings and structures in historic areas and districts.

Preservation: Generally, saving from destruction or deterioration old and historic buildings, sites, structures, and objects and providing for their continued use by means of restoration, rehabilitation, or adaptive use.

Proportion: Harmonious relation of parts to one another or to the whole.

Reconstruction: The act or process of reproducing by new construction the exact form and detail of a vanished building, structure, or object, or a part thereof, as is appeared at a specific period of time.

Rehabilitation: The act or process of returning a property or building to usable condition through repair, alteration, and/or preservation of its features which are significant to its historical, architectural, and cultural values.

Restoration: The act or process of accurately taking a building's appearance back to a specific period of time by removing later work and by replacing missing earlier features to match the original.

Retain: To keep secure and intact. In the guidelines, "retain" and "maintain" describe the act of keeping an element, detail, or structure and continuing the same level of repair to aid in the preservation of elements, sites and structures.

Re-use: To use again. An element, detail, or structure might be reused in historic districts.

Rhythm: Movement or fluctuation marked by the regular occurrence or natural flow of related elements.

Scale: Proportional elements that demonstrate the size, materials, and style of buildings.

Setting: The sum of attributes of a locality, neighborhood, or property that defines its character.

Significant: Having particularly important associations within the context of architecture, history, and relative culture.

Stabilization: The essential maintenance of a deteriorated building as it exists at present, establishing structural stability and a weather-resistant enclosure.

Streetscape: The distinguishing character of a particular street as created by its width, degree of curvature, paving materials, design of the street furniture, and forms of surrounding buildings.

Style: A type of architecture distinguished by special characteristics of structure and ornament and often related in time; also a general quality of a distinctive character.

C. GLOSSARY OF TERMS

Apron: A decorative, horizontal trim piece on the lower portion of an architectural element.

Arch: A construction which spans an opening and supports the weight above it. (see flat arch, jack arch, segmental arch and semi-circular arch).

Attic: The upper level of a building, not of full ceiling height, directly beneath the roof.

Baluster: One of a series of short, vertical, often vase-shaped members used to support a stair or porch handrail, forming a balustrade.

Balustrade: An entire rail system with top rail and balusters.

Bargeboard: A board which hangs from the projecting end of a gable roof, covering the end rafters, and often sawn into a decorative pattern.

Bay: The portion of a facade between columns or piers providing regular divisions and usually marked by windows.

Bay window: A projecting window that forms an extension to the floor space of the internal rooms; usually extends to the ground level.

Belt course: A horizontal band usually marking the floor levels on the exterior facade of a building.

Board and batten: Siding fashioned of boards set vertically and covered where their edges join by narrow strips called battens.

Bond: A term used to describe the various patterns in which brick (or stone) is laid, such as "common bond" or "Flemish bond."

Bracket: A projecting element of wood, stone or metal which spans between horizontal and vertical surfaces (eaves, shelves, overhangs) as decorative support.

Bulkhead: The structural panels just below display windows on storefronts. Bulkheads can be both supportive and decorative in design. 19th century bulkheads are often of wood construction with rectangular raised panels. 20th century bulkheads may be of wood, brick, tile, or marble construction. Bulkheads are also referred to as kickplates.

Carrara Glass: Tinted glass widely used for storefront remodeling during the 1930s and 1940s. Carrara glass usually came in black, tan, or dark red colors.

Capital: The head of a column or pilaster.

Casement window: A window with one or two sashes which are hinged at the sides and usually open outward.

Clapboards: Horizontal wooden boards, thinner at the top edge, which are overlapped to provide a weather-proof exterior wall surface.

Classical order: Derived from Greek and Roman architecture, a column with its base, shaft, capital and entablature having standardized details and proportions, according to one of the five canonized modes: Doric, Tuscan, Ionic, Corinthian, or Composite.

Clipped gable: A gable roof where the ends of the ridge are terminated in a small, diagonal roof surface.

Column: A cylindrical or square vertical structural or ornamental member.

Common bond: A brickwork pattern where most courses are laid flat, with the long "stretcher" edge exposed, but every fifth to eighth course is laid perpendicularly with the small "header" end exposes, to structurally tie the wall together.

Corbel: In masonry, a projection, or one of a series of projections, each stepped progressively farther forward with height and articulating a cornice or supporting an overhanging member.

Corinthian order: Most ornate classical order characterized by a capital with ornamental acanthus leaves and curled fern shoots.

Cornice: The uppermost, projecting part of an entablature, or feature resembling it. Any projecting ornamental molding along the top of a wall, building, etc.

Cresting: A decorated ornamental finish along the top of a wall or roof, often made of ornamental metal.

Cross-gable: A secondary gable roof which meets the primary roof at right angles.

Dentils: A row of small tooth-like blocks in a classical cornice.

Doric order: A classical order with simple, unadorned capitals, and with no base.

Dormer window: A window that projects from a roof.

Double-hung window: A window with two sashes, one sliding vertically over the other.

Eave: The edge of a roof that projects beyond the face of a wall.

Ell: The rear wing of a house, generally one room wide and running perpendicular to the principal building.

Engaged column: A pillar that is in direct contact with a wall; at least half of the pillar extends beyond the plane of the wall to which it is attached.

Entablature: A part of a building of classical order resting on the column capital; consists of an architrave, frieze, and cornice.

Fanlight: A semi-circular window usually over a door with radiating muntins suggesting a fan.

Fascia: A projecting flat horizontal member or molding; forms the trim of a flat roof or a pitched roof; also part of a classical entablature.

Fenestration: The arrangement of windows and other exterior openings on a building.

Finial: A projecting decorative element at the top of a roof turret or gable.

Fishscale shingles: A decorative pattern of wall shingles composed of staggered horizontal rows of wooden shingles with half-round ends.

Flashing: Thin metal sheets used to prevent moisture infiltration at joints of roof planes and between the roof and vertical surfaces.

Flat arch: An arch whose wedge-shaped stones or bricks are set in a straight line; also called a jack arch.

Flemish bond: A brick-work pattern where the long "stretcher" edge of the brick is alternated with the small "header" end for decorative as well as structural effectiveness.

Fluting: Shallow, concave grooves running vertically on the shaft of a column, pilaster, or other surface.

Foundation: The lowest exposed portion of the building wall, which supports the structure above.

Frieze: The middle portion of a classical cornice; also applied decorative elements on an entablature or parapet wall.

Gable: The triangular section of a wall to carry a pitched roof.

Gable roof: A pitched roof with one downward slope on either side of a central, horizontal ridge.

Gambrel roof: A ridged roof with two slopes on either side.

Ghosts: Outlines or profiles of missing buildings or building details. These outlines may be visible through stains, paint, weathering, or other residue on a building's façade or side elevation.

Guardrail: A building component or a system of building components located at or near the open sides of elevated walking surfaces that minimizes the possibilities of a fall from the walking surface to a lower level.

Handrail: A horizontal or sloping rail intended for grasping by the hand for guidance or support.

Hipped roof: A roof with uniform slopes on all sides.

Hood molding: A projecting molding above an arch, doorway, or window, originally designed to direct water away from the opening; also called a drip mold.

Ionic order: One of the five classical orders used to describe decorative scroll capitals.

Jack arch: (see Flat arch)

Keystone: The wedge-shaped top or center member of an arch.

Knee brace: An oversize bracket supporting a cantilevered or projecting element.

Lattice: An openwork grill of interlacing wood strips used as screening.

Lintel: The horizontal top member of a window, door, or other opening.

Luxfer glass: A glass panel made up of small leaded glass lights either clear or tinted purple. These panels were widely used for storefront transoms during the early 20th century.

Mansard roof: A roof with a double slope on all four sides, with the lower slope being almost vertical and the upper almost horizontal.

Masonry: Work using brick, stone, concrete block, tile, adobe or similar materials.

Massing: The three-dimensional form of a building.

Metal standing seam roof: A roof composed of overlapping sections of metal such as copper-bearing steel or iron coated with a terne alloy of lead and tin. These roofs were attached or crimped together in various raised seams for which the roof are named.

Modillion: A horizontal bracket, often in the form of a plain block, ornamenting, or sometimes supporting, the underside of a cornice.

Mortar: A mixture of sand, lime, (and in more modern structures, cement), and water used as a binding agent in masonry construction.

Mullion: A heavy vertical divider between windows or doors.

Multi-light window: A window sash composed of more than one pane of glass.

Muntin: A secondary framing member to divide and hold the panes of glass in multi-light window or glazed door.

Oriel window: A bay window which emerges above the ground floor level.

Paired columns: Two columns supported by one pier, as on a porch.

Palladian window: A window with three openings, the central one arched and wider than the flanking ones.

Paneled door: A door composed of solid panels (either raised or recessed) held within a framework of rails and stiles.

Parapet: A low horizontal wall at the edge of a roof.

Pediment: A crowning element, generally triangular, forming the gable of a roof; any similar element used over windows, doors, etc.

Pier: A vertical structural element, square or rectangular in cross-section.

Pilaster: A rectangular pillar attached, but projecting from a wall, resembling a classical column.

Pitch: The degree of the slope of a roof.

Portico: A roofed space, open or partly enclosed, forming the entrance and centerpiece of the facade of a building, often with columns and a pediment.

Portland cement: A strong, inflexible hydraulic cement used to bind mortar.

Pressed tin: Decorative and functional metalwork made of molded tin used to sheath roofs, bays, and cornices.

Pyramidal roof: A roof with four identical sides rising to a central peak.

Quoins: A series of stone, bricks, or wood panels ornamenting the outside of a wall.

Restoration: Returning a building to the exact form and detail as it appeared at a certain point in history.

Ridge: The top horizontal member of a roof where the sloping surfaces meet.

Rusticated: Roughening of stonework or concrete blocks to give greater articulation to each block.

Sash: The moveable framework containing the glass in a window.

Segmental arch: An arch whose profile or radius is less than a semicircle.

Semi-circular arch: An arch whose profile or radius is a half-circle the diameter of which equals the opening width.

Sheathing: An exterior covering of boards of other surface applied to the frame of the structure. (see Siding)

Shed roof: A gently-pitched, almost flat roof with only one slope.

Sidelight: a vertical area of fixed glass on either side of a door or window.

Siding: the exterior wall covering or sheathing of a structure.

Sill: The bottom crosspiece of a window frame.

Spindles: Slender, elaborately turned wood dowels or rods often used in screens and porch trim.

Stretcher bond: A brickwork pattern where courses are laid flat with the long "stretcher" edge exposed.

Surround: An encircling border or decorative frame, usually at windows or doors.

Swag: Carved ornament on the form of a cloth draped over supports, or in the form of a garland of fruits and flowers.

Terra cotta: Decorative building material of baked clay. Terra cotta was often glazed in various colors and textures. Terra cotta was widely used for cornices, inset panels, and other decorative façade elements from ca. 1880 to 1930.

Transom: A horizontal opening (or bar) over a door or window.

Trim: The decorative framing of openings and other features on a facade.

Turret: A small slender tower.

Veranda: A covered porch or balcony on a building's exterior.

Vergeboard: The vertical face board following and set under the roof edge of a gable, sometimes decorated by carving.

Vernacular: A regional form or adaptation of an architectural style.

Wall dormer: Dormer created by the upward extension of a wall and a breaking of the roofline.

Water table: A projecting horizontal ledge, intended to prevent water from running down the face of a wall's lower section.

Weatherboard: Wood siding consisting of overlapping boards usually thicker at one edge than the other.

Louisiana State Income Tax Credit Program for Rehabilitated Historic Property

Louisiana administers two state tax credit programs for the rehabilitation of historic buildings. One is for commercial buildings, the second for residential buildings. The former must be income-producing, while the latter must be owner-occupied, or at least 50 years old if vacant. In either case, the building must have a historic designation, such as belonging to a historic district or being listed on the National register of Historic Places. (Please see the following table.)

This incentive program is designed to encourage rehabilitation of both residential and commercial historic buildings. Property owners must continue to own the building for five years following the rehabilitation, or forfeit the tax credit. The State Commercial Tax Credit may be used in addition to the Federal Historic Rehabilitation Tax Credit. It may also be combined with the State Residential Tax Credit, if the building is mix-use.

For more information, please visit the website of the Louisiana Department of Culture, Recreation, and Tourism:

http://www.crt.state.la.us/hp/tax_incentives_program.aspx

Or contact the Louisiana Department of Culture, Recreation, and Tourism directly for first time inquiries on tax credits at (225) 342-8160.

Tax Credits for Historic Buildings in Louisiana

	Federal Historic Rehabilitation Tax Credit	Louisiana State Commercial Tax Credit	Louisiana State Residential Tax Credit
What is eligible?	Building listed on the National Register individually or within an NR historic district; must produce income.	Income-producing building within a Downtown Development District or Cultural District, as designated by the Division of Historic Preservation.	Owner-occupied building listed in an NR district, a locally designated district, a DDD or CD, or a Main Street district; a vacant or blighted building at least 50 years old.
% of Credit	20% of construction costs and fees	25%	25% credit=AGI \$50,000/less; 20% credit= AGI \$50,001-75,000; 15% credit= AGI \$75,001-100,000; 10% credit=AGI \$100,000+. (Available only for vacant/blighted residences 50 years or older.)
Minimum expenditure	Must exceed the adjusted basis of the building; \$5,000 minimum	\$10,000	\$20,000
Fees	\$250 + final fee based on size of rehabilitation	\$250	\$250
Recapture	If the owner sells within 5 years, he loses 20% of the earned credit for each year short of the full 5 years.	If the owner sells within 5 years, he loses 20% of the earned credit for each year short of the full 5 years.	If the owner sells within 5 years, all unused credit becomes void.

Resources for Rehabilitation

- Carley, Rachel. *The Visual Dictionary of American Domestic Architecture*. New York: Henry Holt and Company, LLC, 1994.
- Evers, Christopher. *The Old-House Doctor*. Woodstock, New York: The Overlook Press, 1986.
- Harris, Cyril M., ed. *Dictionary of Architecture and Construction*. District of Columbia: McGraw Hill, 2000.
- Kangas, Robert. *The Old-House Rescue Book*. Reston, Virginia: Reston Publishing Company, 1982.
- Labine, Clem, ed. *Clem Labine's Traditional Building*. Brooklyn, New York: Historical Trends Corporation.
- Litchfield, Michael W. *Renovation: A Complete Guide*. New York: Wiley, 1982.
- Longstreth, Richard. *The Buildings of Main Street: A Guide to American Commercial Architecture*. District of Columbia: The National Trust for Historic Preservation, 1987.
- McAlester, Virginia and Lee. *A Field Guide to American Houses*. New York: Alfred A. Knopf, 2006.
- Morton, W. Brown, III, Gary L. Hume, and Kay D. Weeks. *The Secretary of the Interior's Standards for Rehabilitation and Guidelines for Rehabilitating Historic Buildings*. 1979. Rev. ed. Washington, D.C.: Technical Preservation Services. U.S. Department of the Interior, 1990.
- Moss, Roger. *Century of Color*. Watkins Glen, N.Y.: The American Life Foundation, 1981.
- Nash, George. *Old-houses, A Rebuilder's Manual*. Englewood Cliffs, N.J.: Prentiss-Hall, 1980.
- “Old-House Journal”. Monthly. Old-House Journal Corporation, 435 Ninth Street, Brooklyn, New York, 11215.

Park, Sharon D., AIA. *The Use of Substitute Materials on Historic Building Exteriors. Preservation Brief no. 16.* Washington, D.C.: Technical Preservation Services, U.S. Department of the Interior, 1989.

Phillips, Steven J. *Old-House Dictionary.* Lakewood, Colorado: American Source Books, 1989.

Rypkema, Donovan D. *The Economics of Historic Preservation.* Washington: The National Trust for Historic Preservation, 1994.

Technical Preservation Services, National Park Service, U.S. Department of the Interior. *Respectful Rehabilitation.* Washington, D.C.: The Preservation Press, 1982.

_____. *Preservation Briefs.* Published periodically. Washington, D.C.: Government Printing Office.